



An Amateur Radio publication for the Microwave enthusiast

# MICROWAVE NEWSLETTER

Published by the Radio Society of Great Britain and edited by G3PHO and G8AGN.

Lambda House, Cranborne Road, Potters Bar, Hertfordshire EN6 3JE

## FROM THE EDITOR

2003 – OCTOBER

Much of this issue was written at the same time as last month's edition! This was due to your scribe's globe trotting over the end of September and throughout October. While you are reading this he will be enjoying Australian sunshine ... he hopes so! As a result there is a lack of activity news for the past few weeks but that will be corrected in the November edition.

Next month's newsletter will be the usual bi-monthly one, spanning November and December, so as to avoid the Christmas mail "log jam". Your articles, news and views are urgently needed for that issue. Please send them to the editor to arrive during the first week in November.

We are particularly indebted this month to Fred Miller, WO2P (W "oh" 2P that is) for his nice article on the CW Dasher, something that is easy to make and most useful for i.d purposes on the microwave bands. This article has also appeared in the U.S.A's Packrats Newsletter. Also from across the Pond comes a thought-provoking article from Dick, K2RIW and an interesting item about waveguide -coax transitions from Randy NR6CA. These latter two articles are courtesy of the excellent Internet discussion reflector run by WA1MBA .. Many thanks Tom!

If you have not yet registered for the **Martlesham Microwave Round Table** then we urge you to do so, for the meeting will have a forum at which very urgent microwave matters will be discussed. We need your input!



### In this issue ...

- Wanted and For Sale Adverts
- Errata - gremlins strike again!
- 24GHz Cumulative Contest Results
- The Dasher - automatic CW dash generator
- Something to think about ...
- Is your dish doing what you think it is?
- It's Your Say ... Open Forum
- Up, up and away in my beautiful balloon
- New European 5.7GHz record?
- Roving in Wyoming ... having fun /P !
- GB3SC# beacon news
- Microwave Update 2003 -- 1st Report
- Activity News and Operating Ladder

News, views and articles for this newsletter are always welcome. Please send them to G3PHO (preferably by email) to the address shown below. The closing date is the Friday at the end of the first full week of the month if you want your material to be published in the next issue.



G3PHO: Peter Day

0114 2816701



G3PHO, Peter Day,  
146 Springvale Road,  
Sheffield, S6 3NU, UK



G3PHO: Email: [microwaves@blueyonder.co.uk](mailto:microwaves@blueyonder.co.uk)  
or [microwaves@g3pho.org.uk](mailto:microwaves@g3pho.org.uk)

**SUBSCRIPTION ENQUIRIES SHOULD BE SENT TO RSGB HEADQUARTERS AT THE ADDRESS SHOWN AT THE TOP OF THIS PAGE AND NOT TO THE EDITOR ..**

## URGENTLY WANTED TO GET G4ZXO ON TO 24GHz !

We have some DB6NT modules and a 2 watt PA is on its way. All we need now is to link them all together! Can anyone help with the following:

**SMA to WG20 transition (1 off)**  
**WG20 90deg E plane bend (2 off)**  
**WG20 straight waveguide with square flanges (various shortish lengths wanted)**

We might need more bends to get everything bolted together at the end of the day but the above should be enough to get started.

**Please contact: Peter Horbaczewskj,  
G4ZXO  
Email: peterh@hotkeys.co.uk**

## FOR SALE

**70cm PA, with 2C39BA output . Professionally made. Up to 100 watts ssb or 50+ watts TV output**

Complete with PSU (but no c/o/relays).

**Price £50 o.n.o.** Delivery may be possible (Telford, Shropshire).

**Phone 01952 255416 or  
email Martyn, G3UKV: ukv@globalnet.co.uk**

## Surplus to requirements:

**DB6NT 10GHz PA** type MKU101H. 2W out from 200mW in. Brand new/unused in original packing with data. **£180** ono (price new from Kuhne ~£290). **Contact Kevin, G1HDQ: knr@fireflyuk.net or tel. 01460 220338.**

## ERRATA ... (1)

*Last month's article "A Slotted Line for 2.4GHz" contained an unfortunate error. Somewhere in the process of converting the author's Word document to the DTP format used by the newsletter, the mathematical symbols used for the formula (and part of the text) were not reproduced correctly. Please amend your copy of the September 2003 Newsletter at the foot of page 5 to read as follows:*

I mounted a 600mm rule on the top of the waveguide to enable  $\lambda_g$  to be measured directly. For 2401 MHz the calculated figure for waveguide of this internal dimensions is 165.5mm. The figure I measured was 166mm. The formula for calculating  $\lambda_g$  is in the Microwave Handbook Vol. 1 p.5.17 but there is a misprint, and the correct formula is:

$$l_g = \frac{1}{\sqrt{1 - (l/2a)^2}}$$

Where  $\lambda$  is the free space wavelength and "a" is the internal dimension of the broad face of the waveguide.

Adjustment of the shorts on the transitions is quite simple. The 2.4GHz source is connected to one transition and a good quality 50 ohm termination is connected to the other, and the maximum and minimum voltages on the line, separated by  $\lambda_g/4$ , are found, and measured, by sliding the saddle along the waveguide.

## ERRATA ... (2)

The German beacon DB0GHZ has been mistakenly quoted ,in both this newsletter and elsewhere, as being in JO43 square. It is not ! Please amend your beacon lists with the following information, direct from Timm, DK1ZD, the beacon keeper:

**QTH locator: JO34WE ( not JO43 WE)**  
**ANTENNA: OMNI**  
**HEIGHT ASL: 55m**  
**LOCATION: Island of Heligoland**

# 24GHz UK CUMULATIVE CONTEST RESULTS 2003

The revision of the annual UK contest programme scheduled, amongst other changes, three 24GHz cumulative contests. In previous years these had been "stand alone" events, held in conjunction with 47GHz and 76GHz.

The results are now available thanks to Steve, G4KNZ, the RSGB Microwave Committee Contest Adjudicator.....

<b>RSGB 24GHz Cumulatives 2003</b>							
		<b>13-Apr</b>	<b>13-Jul</b>	<b>11-Aug</b>	<b>QSOs</b>	<b>Best DX</b>	<b>Points</b>
1	G3PHO/P	333	712	90	13	137km	<b>1045</b>
2=	G3F YX/P	0	716	0	7	137km	<b>716</b>
2=	G4KNZ/P	0	716	0	7	137km	<b>716</b>
4	G8BKE/P	75	215	0	6	76km	<b>290</b>
5	G3LRP	108	172	0	5	64km	<b>280</b>
6	G4BRK	37	0	0	1	37km	<b>37</b>

*Note: QSOs is the scoring QSOs in the best 2 activity periods*

Congratulations to the overall winner, Peter, G3PHO, who made good use of the rover rules, operating from up to 4 sites in one day. Peter's equipment consists of a homebuilt transverter, with a 2W PA, and a 35cm offset dish, tripod mounted at up to 8ft above ground.

From the logs received, a total of 15 stations were active overall. It would have been nice if a few more could have sent in an entry, or even just a check log.

The highest activity was in July, when the weather was excellent, being hot and sunny, but the downside was the high humidity which meant some paths were more difficult to work than usual.

Several operators commented that the timing of the 3 sessions was not optimum, especially the August event - when there was minimal activity due to holidays and clashes with other activities. Another suggestion was to revert back to separately scored events rather than a cumulative.

**Regards, Steve G4KNZ, Adjudicator**

## **DON'T FORGET TO REGISTER FOR THE MARTLESHAM MICROWAVE ROUND TABLE !**

- Held over the weekend of 8-9th November this year
- Full details are appearing on the Internet ... check G4DDK's webpages for links and further information .... <http://www.btinternet.com/~jewell/>

# The Dasher --- an automatic CW dash generator

By Fred Miller, WO2P  
(W "oh" 2P)

The "*Dasher*" was designed and built within two week of our recent 24 gigahertz Marathon. It was built purely out of a need for self-preservation. Standing on a cold windy hilltop and sending (not so well formed) dashes for 5 to 10 minutes at a time with a straight key was, to say the least, uncomfortable. I refrained from using my home station keyer because of the added weight and bulk to an already pretty hefty "portable" station. I wanted something small, light and self contained.

Version one was based on a "blinking led" from Radio Shack. I demoed it at last month's club meeting. It functioned fairly well and was really inexpensive but the dash rate seemed just too slow. The blink rate was preset by the chip internal to the LED. With no way to adjust it, it was back to the drawing board.

The current version seen here is based on a 555 timer. I experimented with various resistor and capacitor values until I arrived at what I think is a good balance. When operational pin 3 will generate regular low going pulses based on the setting of R1. The low going pulse charges C1 and energizes Relay 1 closing the normally open contacts and activating the keyed circuit in the IF radio. When pin 3 goes high C1 discharges through Relay 1 one and delays its release. The length of the Relay 1 release delay is determined by the value of C1. The larger the value of C1 the longer Relay 1 will remain operated. A short period of time later the cycle repeats creating dashes.

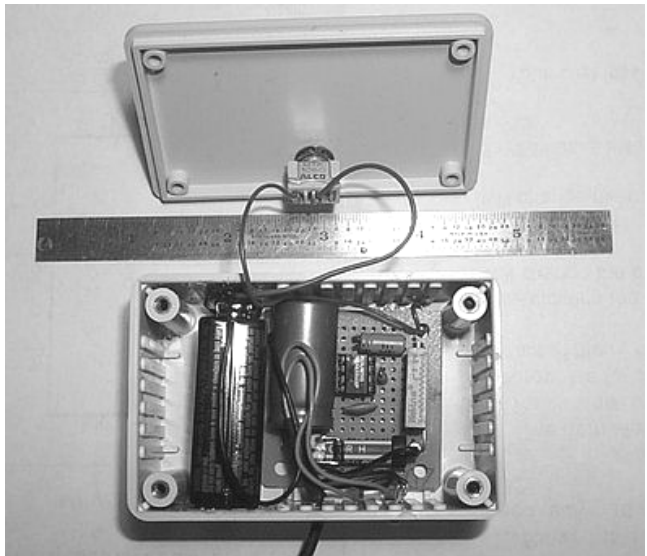

Since my IF radio is an ICOM IC-260 that requires hard keying, I connected Relay 1's normally open contacts to a 2 wire cable with an 1/8" plug on the other end. I inserted a 1/8" "Y splitter" into the IF radio CW key jack and then my straight key plug and dasher plug into the splitter. The straight key and the Dasher are in parallel. When I need to send dashes I just flip the toggle switch on the dasher. When my signal is found I switch off the Dasher and finish the QSO with the straight key. The entire circuit including a 9 volt battery fits into a small 3.5" x 2.5" x 1.5" plastic case that is bungie-strapped to the side of my portable microwave system.

If you are a "hill-top microwaver" and looking for a very inexpensive one evening project give this one a try. You will thank yourself the next time you are out on a cold windy day.

# The "Dasher"

An automatic CW dash generator

## Circuit Notes

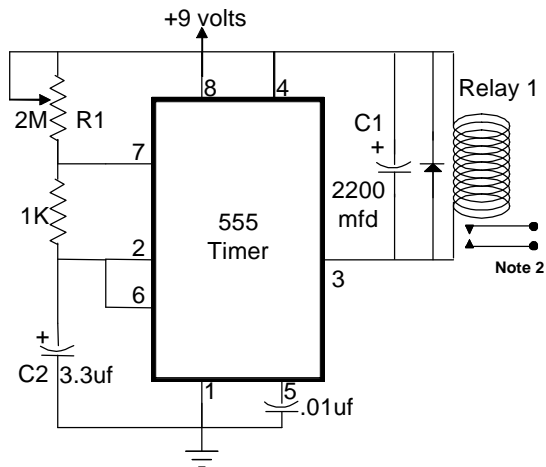

Circuit Designed by:  
Fred Miller WO2P  
4/24/03

1. Relay 1 is a Radio Shack reed relay part number 275-232
2. The normally open contacts of Relay 1 are connected as appropriate for the keying circuit of the IF radio
3. Adjusting the value of C1 will change the dash length
4. Adjusting R1 will change the dash rate
5. Note C1 and C2 are electrolytic capacitors
6. Total cost less than \$10.00

## SOMETHING TO THINK ABOUT WHEN YOU ARE TESTING EQUIPMENT ...

### From the WA1MBA Microwave Reflector:

I have been doing a great deal of work with 5.7 and 10 GHz equipment lately. I have used several waveguide to N or SMA adapters, mostly WR-90 (= *WG16 ... editor*) and WR-75 but also WR-137. What I found, which I am sure many of you know, is they are generally terrible adapters!

For example, the HP X281A WR-90 to N female: they have, on average, a 6dB return loss at 10368MHz. The best one had 7. A Hughes WR-75 to SMA adapter started at 6dB. I was able to tune the Hughes unit to a R.L. of 35 dB -- quite an improvement! My worst HP X281A was 18dB and the other two were 22 and 23 dB. I could tune them better but with little operational impact. A WR-137 adapter started out at 18dB. I was able to tune it to 40dB, yes 40dB, with a single screw (though it had one already!).

My word to the wise, unless you have already done so, is to get your adapters tuned. If you don't have the test equipment, there will certainly be someone who can help. I happen to have return loss measurement capability but I find it just as easy to use a good directional coupler (-30dB coupling), a signal source and my spectrum analyzer.

Don't throw away RF. A low return loss also adds to receiver noise figure. These devices are simple and easy to tune.

Happy microwaving. From Randy, NR6CA



## IS YOUR DISH DOING WHAT YOU THINK IT IS?

From: Richard T. Knadle, K2RIW  
[rknadle@suffolk.lib.ny.us]  
Sent: 18 April 2003  
To: microwave@wa1mba.org  
Subject: [Mw] Dish Efficiency

**INTRODUCTION** -- In his 4/15/03 submittal, Kent, WA5VJB quoted the Johnson & Jasik "**Antenna Engineering Handbook**", **2nd edition, 1984**, page 36-9 as saying that the reference #16 article authors (Galindo-Israel, Mittra and Cha) are claiming that, "Their analytical techniques are reported to result in efficiencies in the 80 to 90 percent range". Kent is accurately quoting the Handbook, but there is a problem -- I believe the quote is being taken out of context. I'll supply 3 pieces of evidence of this, and I'll provide a further discussion of possible Dish Efficiencies.

(1) Chapter 36 of the Handbook is devoted to "Earth Station Antennas" that are 60 to 300 wavelengths in diameter. As you are about to find out, some great "efficiency magic" is possible when you have a lot of wavelengths to play with.

(2) The type of antennas being discussed on page 36-9 are Double-offset Geometry dish antennas. This means that the feed horn is offset from the hyperbolic-like subreflector, and the subreflector is offset from the parabolic-like main reflector. These are rather complicated geometries that our Microwaver's may not be able to use, for some time to come (explained below).

(3) The "Analytical Techniques" being discussed are computer-modelled theoretical dish antennas that are using a Cassegrainian-like geometry that employs a "shaped" reflector and subreflector. This means that the main reflector is an intentionally distorted parabola, and the subreflector is an intentionally distorted hyperbola. The intentional distortions are being used to simultaneously improve the "Illumination Taper" while still providing essentially no unintended "Phase Taper". The computer-modelling techniques had to use "Diffraction Optimization" techniques for which there is no exact Geometric Optics (GO) solution -- whew!

**MAXIMUM DISH EFFICIENCY** -- I wish we had access to 90% aperture efficient Dish Antennas, and Horn Antennas. We usually do not, and you will soon see why. "Aperture Efficiency" and Sidelobe Levels are often misunderstood, and the detriment they cause is often misquoted. I hope the following material will help.

**IT'S ALL IN THE FEED SYSTEM** -- The requirements for high efficiency are easy to state, but quite hard to achieve. So, what's required for 100% efficiency -- no Phase Error (no phase taper), and no Amplitude Taper. If my great new "wizz-bang" feed horn system could provide exactly the same number of watts per square cm across my parabolic reflector, no spill-over energy at the edges, and no phase errors, than I'd have what's called a 100% Aperture Efficient dish antenna system.

**TRANSMISSION & RECEPTION** -- During transmit, almost every possible watt emitted by the antenna would be directed toward the target, and during reception, almost every "possible bit" of the signal hitting the antenna (from the correct direction and polarization) would be absorbed and sent down the feed line -- and it would often peg the S meter. If I had such an antenna, there

would be no way that I could improve the transmission or reception, without increasing the size of the antenna.

**SIDE LOBES & SCATTERING** -- However, newly-instructed antenna engineers are usually quite surprised to find that a theoretical 100% Aperture Efficient (round dish) antenna will still have 1st side lobes that are about 17.5 dB down, and on reception the antenna still has a considerable "Scattering Area" that will show up on a good Instrumentation Radar.

**SIDE LOBE ORIGIN** -- The sidelobes are the result of the Diffraction Effect, caused by the abrupt fall-off of signal at the edge of the antenna. Simplistically, you could say that Mother Nature doesn't like a sharp discontinuity, and she responds by creating those pesky side lobes (they're almost always there).

**SCATTERING ORIGIN** -- A Free Space vacuum has an "impedance" of  $120 \cdot \pi$  (377 ohms). The 100% Aperture Efficient, highly directional, dish antenna, will absorb the maximum signal if it also presents a matched impedance of 377 ohms. However, now there is a 377 ohm antenna across (in parallel with) the free space impedance of 377 ohms. The new local impedance is now  $377/2 = 188.5$  ohms. A free-space planar wave entering the vicinity of the antenna will "sense" the change in impedance, and a portion of the wave will become scattered at the impedance discontinuity.

**MAKE IT DISAPPEAR** -- There are ways to make the antenna sidelobes as low as you like, and there are ways to lower the Scattering Area as much as you please. But, all of these techniques must be accompanied by an Aperture Efficiency that is considerably lowered -- you can't have it both ways.

**IT'S ALL IN THE SIZE OF IT** -- I can almost achieve that nearly ideal Illumination Taper (0.0 dB) and Phase Taper (0.0 degrees). However, to have that much control over the radiation characteristics (primary pattern) of the Feed will require the horn to be made from a very large number of radiating elements that have a carefully-controlled amplitude and phase at each element. Such a "Cluster Feed" would really be an elaborate Phase Array Antenna, and I don't think you can come close to achieving the desired primary pattern with less than 1,000 elements -- a feed with about 38 wavelengths of diameter (43 inches [1.1 meters] at 10 GHz).

**SMALL CASSEGRAINS** -- I'm always amused when I encounter an enthusiastic, new Microwaver who becomes enthralled with a small-dish Cassegrain antenna system. Quite often they end up with a subreflector design of 1.5 inch diameter at 10 GHz, and they start to worry about the accuracy requirement for the Hyperbolic shape. There is a tried-and-true rule of thumb among informed antenna engineers, "don't even consider a Cassegrain system unless the subreflector is at least 10 wavelengths in diameter".

A 1.5 inch subreflector at 10 GHz (1.3 wavelengths) is essentially a "Point Source" (almost isotropic). If your eyes functioned at 10 GHz, and you looked at an illuminated 1.5 inch subreflector, it would look like a fuzzy white dot to you, and you couldn't tell if it was concave, convex, or flat -- they would all look the same. It takes a large number of wavelengths of object size before your "vision system" begins to resolve the details. The 2 inch diameter of the subreflector on my 8 inch Celestron Cassegrain telescope is 100,000 wavelengths in diameter -- that's a real subreflector that can easily control the pattern it reflects!

**CONCLUSION** -- Concerning those super Aperture Efficiencies we sometimes hear about, they are possible, but difficult to achieve. And, I doubt we will see many of these in our back yards, unless we are talking about elaborate antenna designs that are hundreds of wavelengths in main dish diameter.

**73 and Good UHF/SHF/EHF DX,  
Dick, K2RIW.**

**Grid: FN30HT84DC27.**

**Web: <http://consult-li.com/listings/RKnadle.htm>**



## IT'S YOUR SAY .....

### Subject: Re: The future of the microwave bands in the UK

This month we publish a number of replies to the letter from Noel, G8GTZ, printed on page 11 of the September 2003 issue. Where the editorial scissors have had to be wielded, the main argument of the letter has still been preserved! Once again, as always, we must state that the views expressed in this column are those of the contributors and are not necessarily those of the Newsletter editor and the RSGB Microwave Committee.

#### From: Grant Hodgson [grant@ghengineering.co.uk]:

The announcement about **432MHz** was also in Radcom. I wonder how many readers actually realise the significance of this single paragraph, printed with no editorial comment or any other supplementary information?

**1.3 & 2.3GHz** - The last ATV repeater licences were issued in January this year, I think: it will be interesting to see when the next ones are issued. Actually, it won't be interesting - it might be very boring - waiting, and waiting - and waiting....I spoke to two of the RMC members at the Amsat Colloquium at length in July, and I am fairly happy that the RMC are doing absolutely everything they can to push the new licence applications through. The problems lie with both the primary users and the RA. The primary users now seem to have a policy of refusing all repeater applications on the bands for which they have primary status (and we have secondary status). This is a fairly recent development and we can only hope that the attitude of the Primary users changes, but don't hold your breath.

The other problem is the RA. I thought it was their job to act as an intermediary between the various users of the spectrum but it would seem that either they are unable, or unwilling, to reason with the primary users at any sort of level, technical or otherwise, and help to progress the repeater applications. I have heard various comments about OFCOM (organisation for curtailment of microwaves???) that would seem to agree with your comments. ***(G3RZP's comments later ..editor)***

I would add that we have the lower part of the **24GHz** band on a PRIMARY basis, with the proviso that we must accept interference from ISM users

(Industrial, Scientific and Medical). I would guess that the chances of interference on 24GHz from ISM users is pretty slim at the moment and, without another WARC, we will continue to have primary status. However, it would indeed seem unlikely that we are going to get any more repeaters licenced on the other bands for some time, which is a shame for a number of reasons.

I don't know why Noel didn't get a reply from the RMC, but I am sure that they are doing everything they can do progress the various applications. I don't know about the Microwave Committee though - you can't expect the General Manager to have the answers to every specific query in a hobby as diverse as ours, and so it would seem reasonable to pass this on to a specialised committee, who should have been able to give a reply.

As for **7MHz** - the policy of the RSGB seems to have been to play 'the numbers game' for some time now: that is to appeal to the maximum number of members or potential members and not worry too much about the stuff above 144MHz which is only of interest to a minority. ATV, satellites and of course microwaves only get one page in Radcom every two months, and the number of words per page has actually decreased since the move to the horrible tabloid style headers with the huge left and right page margins a few months ago!

The introduction of the M3 callsigns is definitely a good idea, but there is now practically no incentive for any newcomers to experiment with anything above 144MHz - gone are the days when many newcomers would serve an 'apprenticeship' on 2m, with all the different propagation modes and other interesting aspects that VHF had (still has) to offer, which in turn lead the small minority (i.e. those reading this now) to see what life is like with even higher frequencies. It is now relatively easy to get straight onto the HF bands and make DX contacts and that is as far as it goes for many newcomers. So we have the classic 'Catch 22': the RSGB say that the vast majority of members are not interested in the higher frequencies; they produce a (still good) monthly magazine that has very little space for microwave issues, which in turn leads the bulk of the membership to think that there isn't much point in getting involved in microwaves - there can't be many people up there because they hardly get a mention in Radcom!

It seems to me that the minority interest groups do not get a lot of support from the RSGB management.

Let's hope that the attitude of the RA/OFCOM and the primary users of bands above 432MHz changes soon, and that the new repeater licenses are issued which should generate a number of new construction and experimentation projects on the microwave bands.

Lets hope.

**73 Grant Hodgson, G8UBN**

**From: Freddy de Guchteneire ON6UG**

**[on6ug@amsat.org]**

**Sent: 05 September 2003**

I fully agree with the comments from Grant and I recommend that the microwave community think about the future, have discussions at rallies and meetings and somehow let the RSGB microwave group know about our thoughts. It is important that we have a strategy for protecting our microwave bands.

**Sincerely, Freddy de Guchteneire**

**From: Peter Chadwick, g3rzp@btopenworld.com**

**Sent: 10 September 2003**

G8GTZ is quite right to be worried by the advent of OFCOM. We all need to be. The RA, although the largest part of OFCOM, and the largest financial contributor, have the fewest senior managers in it. I know a number of people in the RA are very worried, even though the redundancy package isn't too bad when compared with industry. Worse in many ways, is that the representation for amateurs and UK plc at international fora such as CEPT and ITU may well diminish, and make no mistake, there's a lot done for amateur radio at these fora by the RA.

However, **the pressure on the microwave bands has not only always been there.** It always been fuelled to a greater or lesser extent by the fact that on the 'use or lose' stakes, amateurs don't come out very well. I know, it's because it's not as easy as an HF black box ... you actually have to have some sort of clue about what you're doing, and you may have to go out on cold hillsides. Activity /kHz isn't what it desirably should be. I believe however, that the situation has been compounded by the disbanding of the RSGB Licencing Advisory Committee, (see page 5 March 2003 *RadCom ... editor*) where the technical expertise lay. Remember that I say this having been on Council for six of the last ten years and am a Past President to boot! There're one or two other Past Presidents who agree with this view too. Once G3YGF was no longer involved in LAC, we were bound to see matters glossed over when the technical level of consultation with the RA was required to be other than mundane.

I'm not so sure the WLAN at 5GHz will be such a major problem as it uses a listen-before-talk protocol. The schemes do use OFDM (Orthogonal Frequency Division Multiplex) which means linear PAs. So I expect there will be some relatively cheap linear 100mW or so PA stages around if and when it takes off. So there might be a bit of light in the darkness.

Some of us are still doing what we can. I represent IARU at Task Group 1/8 of ITU on Ultra Wide Band, Arie, PA0EZ represents IARU at CEPT SE24 on Short Range Devices, where I often go in my professional capacity, and of course assist where possible ... but it is a long uphill struggle, I admit.

**If more people used microwaves, it would be easier.....**

**vy 73 from Peter, G3RZP**

**From: Kevin Ravenhill, G1HDQ**

**[knr@fireflyuk.net] Sent: 31 August 2003**

At the risk of being accused of doom-mongering, some food for thought:

The email (indirectly from Noel G8GTZ and the UK\_ATV mailing list) underlines previous comments of myself & others about commercial pressures on 24GHz and indeed most of the rest of the UHF/microwave spectrum. Noel's comments are in line with the noises I have been hearing from my own sources and the whole picture remains a worrying one.

Management of the RF spectrum is radically changing, with control being largely handed over to money men. As is all too often the case now, profit will be the prime driver of the new arrangements with frequencies being auctioned off to whoever can pay the most. There will be little room for altruism or forward thinking. Radio amateurs are a soft target and in the worst-case scenario, we could literally be priced out of the market and lose considerable chunks of spectrum - unless we come up with a convincing argument as to why we should be allowed to keep them for free, or are prepared to take an order-of-magnitude hit on the licence fee to retain them.

We are not the only people affected by this. Both the CAA and the Home Office/MoD have large chunks of spectrum which have previously been underused and are now under threat from commercial interests - which I imagine is why they're now throwing their weight around and making the most of their primary user status in an effort to repel boarders before it's too late. Unfortunately this directly affects us, of course.

What is not mentioned is that 3.4GHz as well as 5.6/5.8GHz has been allocated to fixed wireless access (local-loop internet as an alternative to ADSL), with licences having recently been granted following an auction. We can therefore expect to see a big increase in commercial usage of this band.

Seems to me it's time to take a considered approach, to consolidate and to present a united front, not only in the UK but across Europe. **Where we have primary allocations we should all use them in preference and gather there in numbers** because secondary allocations could (will?) eventually be truncated or even withdrawn. Like it or not, this is the new reality and there is no room for complacency or sticking our heads in the sand and hoping it will all go away.

**Vy 73 Kevin, G1HDQ**

**Editorial Comment:**

***This is a serious debate and is worthy of everyone's consideration. This subject and other related topics (such as the recent abolition of the RSGB Microwave Committee) will form the core of the Open Forum at November's Martlesham Microwave Round Table. Be sure to be there! Your opinions will be most welcome!***

## Up, Up and away in my beautiful balloon ...

### SKY VIEW High Altitude VideoCam (SKYCAM) Balloon Flights Friday, 12th Sept 2003. Frequency: 2.48GHz

**From: Roy Powers, G8CKN**  
**[mailto:antenna@zetnet.co.uk]**  
**Sent: 12 September 2003**

**First launch** was at 0730z and the local area (South Hampshire), I.O.W and as far a London could be seen between 2000 and 40,000 feet but through quite a bit of cloud/haze. Winds took the balloon cam towards the French Coast - I don't think the coast was seen but, at a maximum height of over **50,000 feet**, the balloon 'burst' and during its initial 'tumble' the earth curvature/ space were seen. The payload is thought to have landed in the sea.

Technical details: Approx 20W erp from VidCam TX. Camera aperture too open so pictures a bit 'white'. Measured temp during flight -18deg at 19,000 ft. Possibly some ice on camera lens as temperature continued to decrease. With a quick lashup RX and 17dBi plate antenna (no rotate and tilt facility) on garage roof approx 15 ft agl, I saw up to P3 quality pictures direct.

**Second launch** was at 1127z ,after false start & replacement of a leaking, then torn balloon. The camera setup this time was much better but with this payload only about 4/5W erp TX. Good pictures were seen of South Hampshire then the I.O.W ( track nominally SE) after a long period 'rolling' round the I.O.W's southern most coast, whilst rising above mixed cloud base. Le Havre and the Seine were thought to be visible (directly below). This balloon had possible ground landing. Temps of -60deg were measured at 45,000 ft. We tended to loose reliable telemetry at 66,000 ft but this returned to indicate a height of **68,000 feet+** when the balloon finally burst. Spectacular pictures of the Earth curve, edge of space and cloud levels were received as the payload tumbled back to earth. It took a surprisingly long time to come down! I think the return speed was about 160mph. With my lashup I received up to P4 quality picture direct at 2480MHz. John MOJTT received up to P5 pictures

with a short yagi inside his car at some 10kilometers from the Launch site and latter was still able to catch flashes of signal at low horizon on a 'local hill' possible during final few thousand ft of the 'French' landing ... not seen by the Control Station due to local terrain and trees.

Live Sky Cam pictures were seen via ATV repeaters, GB3AT Winchester and 'sent on' to GB3HV High Wycombe most of the day from 0730Z to 1730+. Recordings were made at Control station of course and by my self. John, MOJTT had to race round his morning Postal Round to get to see the second flight so unfortunately he only had the basic 13cm Rx kit and no video recorder.

This was a most successful experiment. I look forward to any future flights if this possible.

All details in this report are open to correction but are considered substantially true. More information/full report hopefully forthcoming later from 'The Balloon Management'.

**Regards from Roy, G8CKN**

### NEW 5.7GHz EUROPEAN RECORD ?

**From: G3XDY [g3xdy@btinternet.com]**  
**Sent: 17 September 2003**

There seems no end to the superb tropo this year..... I worked **OK2BFH** on Wednesday morning (17th September) for what I believe to be a new Eu record on 5.7GHz. He is in **JN99FN, I am in JO02OB** and depending on what program you use **the distance is in the range 1240 - 1245km**. We exchanged 559 reports on CW.

**This followed a QSO with him on 10GHz** for my personal best DX on that band. I saw his DX Cluster spot that he was calling towards DJ6JJ, so on the (very) off chance I took a listen around 10368.100 with the dish in the right direction and nearly fell off my chair when I heard him calling CQ on CW. He was 529 with me and gave me 539. We then QSYd to make the 6cm QSO, unfortunately he did not have 9cm or 13cm.

I later heard him on 23cm but only at 529, and I was just switching off to go to work so did not call him.

**(More information next month ... editor)**

# Roving in Wyoming



OF

MURPHY'S LAW .. AS APPLIED TO MICROWAVES

**Editor's note ... this sorry, but nevertheless amusing, tale appeared on the USA microwave reflector a couple of months ago. Many thanks to its author Jess, NOSWV .... my own UK portable exploits will never be the same!**

The last time I went roving, starting in Wyoming, I found out my 6M radio was only semi-functional. I got a flat tyre. A bird hit my antenna and "doinked" a couple of elements. A piece of road debris (a half sheet of plywood) was kicked up by a semi-tractor and hit my car.

I figured that I would have better luck this time. Guess again.....

I came upon a family from Michigan who decided to hunt antelope with the family station wagon. I had to put the animal down myself. The wife was mad, the kids were upset and the husband was pretty much in shock. I had to unload all my gear to take the wife and kids 25 miles into town. I left the husband behind to stay with my gear and their wagon and offered my bottled water and sodas to the husband.

I took the folks into town and helped them arrange a tow truck for their vehicle. Then I provided directions and GPS coordinates for the tow truck driver. On returning to the scene to recover my gear and get back in the contest, the husband tells me my CB doesn't work. I didn't know I had a CB! It turns out he tried to get my 440MHz FM radio operating to call for help. He must have wiped out the finals I think as the radio has no output now.

I packed my stuff and headed for my operating spot, unpacked the truck again and set everything out in order for set up. Then I

heard something like a person walking on tree branches. I looked around and saw a bear! I dropped everything I had in my hands and ran and to get in the truck. I watched the bear charge the truck smashing the HB 16 element 222MHz yagi that I had only just built this Friday afternoon. The bear stepped on the driven element, crushing it and tearing off the balun. He/She/It stomped some of the loops on my 1296 antenna also so I could only run one of the loop yagis instead of the pair. Thankfully, he didn't stomp the 432MHz yagi or it would have been all over. I sat in the truck for about 30 minutes wondering if he was gone.

Once I got everything set up I worked a couple of stations and then took everything down. This is a roving station mind you. I checked my grid map and picked out a nice spot around 6600 feet just north of Cheyenne. Most of these spots are private property and unfortunately I couldn't get anyone to give me permission to set up for a couple of hours. Someone also called the local police....

So, I explained who I was, produced all the usual documents and showed all the things that Johnny Law wants. This was not the first time that I have had dealings with them but this guy was more curious than usual. He made me unpack the truck so he could see all the equipment. Then he wanted to search my truck and wanted to know what the tools were for. At this point a Camaro with no hood and no roof went flying by, with another constable in hot pursuit. I was told to wait until he got back and then he took off.

After 30 minutes he came back and told me I could go. I could tell this one was not the sharpest tool in the shed!

I did find a nice place just northwest of Cheyenne, at about 7700 feet. I couldn't get to it because it was getting too dark to be fooling around and, considering my recent spate of luck, decided that roving in Wyoming is bad jujuu.....

**73 from NOSWV Jesse**

## STOP PRESS! RSGB BOARD ABOLISHES MICROWAVE COMMITTEE

**A decision to abolish the HF, VHF and Microwave spectrum committees was taken at a recent RSGB board meeting and announced in the October 2003 issue of RadCom. An "umbrella" committee or Spectrum Forum is due to replace it after 31 December this year. We have no idea of its make up but we can be sure that most of the various expertises held by the present Microwave Committee will no longer be represented or available to the new forum. This decision, taken without prior consultation with committee members, has far reaching implications, not the least of which is the future of this newsletter and microwave contests. It is essential that your voice is heard. Please make every effort to come to the Martlesham Round Table where this situation will be discussed at some length we think!**

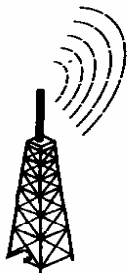

## **GB3SC~ Beacon Progress update (as of 12 September 2003)**

On Friday Sept 12 , GB3SCS on Bell Hill, Loc IO80UU58, was returned to service. The multiplier drift with temperature problems appear to have been solved by changing the L/C ratio on one of the intermediate filter stages to give a lower Q, wider bandwidth design. Its frequency, when I measured it this afternoon, was

2320.902MHz +/- 1kHz.

The 24GHz beacon GB3SCK has now been taken off air for retuning to 24048.900MHz, by Chris G8BKE. Hopefully this will be a straightforward task.

GB3SCX is still undergoing its major rebuild. I am looking at the best way to achieve a high stability, phase locked performance without trying to lock an overtone crystal oscillator. This is undesirable as it results in an inherent low loop bandwidth and so gives potential for frequency wandering around its nominal frequency - not something that is desirable for a narrow band beacon designed for SSB reception!

Metalwork is being constructed to allow reliable heatsinking of the new PA in the head unit, which dissipates over 20 Watts, in all weather conditions. Since the head unit can be exposed to outside temperatures of 38 deg with the sun shining directly on it (if the weather of August is repeated) we need to make a good job here.

No decision has been taken on whether the 45s ON / 45s OFF switching cycle of GB3SCC on 5.76GHz can be changed. During the winter period it could probably be raised to a higher duty cycle but, with no spare PA to repair the head unit if it does go pop, I'm reluctant to do so. All offers of 5.76GHz PA modules gratefully received! As I can't continuously monitor this beacon from home, accurate frequency measurement is not possible at this stage.

GB3SCF, remains on FSK keying with its callsign-only identification. This beacon is so reliable and just sits there operating, that I feel it is tempting something or other to dive inside and change anything for the sake of it, much as I would like to convert to on-off keying and replace the keyer with one that can be reprogrammed on site, as in all the rest of the beacons. Frequency, as measured a couple of days ago, was 3400.905MHz +/- 1kHz.

All antennas are operating at reduced height, as reported last time. The mast will only be wound back up when both the two high frequency beacon rebuilds are completed

As for the sixth beacon on site - G4JNT/P on 70.31MHz with 0.2W EDRP is a useful frequency standard and tuning signal for several locals building transverters for this band. Accuracy is maintained to within a couple of Hz by using a DDS to derive its carrier from a 10MHz ovened oscillator. Data is transmitted as FSK, derived by reprogramming the DDS for mark and space frequencies and is currently set at exactly 85Hz shift. The transmitted data consists of beacon shack telemetry, transmitted using 1s dot period slow CW (known as QRSS to the LF community) to indicate AC mains voltage and current, DC battery voltage, shack temperature and the status of two switches. The data is repeated in fast CW followed by callsign and locator identification before returning to slow CW mode.

**Andy, G4JNT**

## MICROWAVE UPDATE ~ SEATTLE USA SEPTEMBER 2003



No, your eyes are not deceiving you! This remarkable “rover” setup, on a very well worn, almost “beaten up” old VW campervan, was just one of many interesting attractions at the 2003 Microwave Update this year. Held at the Holiday Inn, Everett, near Seattle in the Pacific North West region of the USA, over the last weekend of September, the meeting was attended by over 100 microwavers, including G3PHO and G3PYB. A full report will appear in the November issue of the Microwave newsletter but, for the present, we will dwell on this unusual vehicle! It features beam antennas for 50MHz through to 2.3GHz, all mounted on the roof of the campervan and rotated by what appears to be a Ham-M rotator! Inside the van is a large array of transceiver and other gear. Plus large horns for 5.7GHz and 10GHz.

The van is regarded by the local W7 amateur population as one of the area’s main attractions! It’s proud owner and operator Eric, KB7DQH, is a regular participant in the various UHF and microwave contests around Seattle and drives the “beast” into remote mountain areas, armed with a chainsaw (seen here strapped to the rear left side of the van to chop down interfering tree branches that might get in the way of his signals! We believe he sometimes lowers the antenna farm while driving on the freeways but apparently the present setup is perfectly legal as it is deemed to be a stable load (it’s welded to the roof rack system!).

No photographs can do justice to Eric’s van .. You have just got to see it “in the flesh” to appreciate it. Peter, G3PHO, spent quite a time talking to it’s owner, whose eyes lit up when he found the British visitor had also “roved” in similar vehicles over in the UK! However the similarity ends there .... Peter’s van looked like a Rolls Royce in comparison!

Believe it or not, Eric has even won a plaque at a local VW “vanfest”. He came third place out of three entries but at least he made the effort to submit his pride and joy to the expert judges.

**More on Update 2003 next month!**



# ACTIVITY NEWS FROM THE WORLD ABOVE 1000MHz

## IMPORTANT NOTICE!

Just as this edition of the Newsletter was going to press, members of all of the RSGB spectrum committees (including your own Microwave Committee) each received a letter from RSGB HQ. The letter detailed important and far reaching changes, effective from 1 January 2004. It is highly likely that notice of the changes will already have appeared in RadCom by the time you read this but the implications of the decisions made have far reaching effects that can only be made clear in a later issue of this newsletter ... so

## WATCH THIS SPACE!

Some of the news in this column is that left over from the September newsletter ... there just wasn't enough space left then! Of particular interest in the following reports is the one from G4ALY who is working some super DX on 23cm, 6cm and 3cm. There's also a short note on 24GHz EME from G4NNS. So read on .....

**From: Keith, GW3TKH, South Wales**  
<GW3TKH@aol.com>

### Subject: Flatholm Island operation

I joined the Barry Amateur Radio Society trip to Flatholm Island for the IOTA contest, 26th & 27th July, taking my portable 10GHz equipment, 100mW to a 60cm dish, battery powered. We arrived late Thursday 24th, and with the assistance of Brian, GW3WBU, we erected the operating tent and antennas at Castle Point, IO81KJ. We were about 7m from the cliff edge and 15m asl with a clear take off from 315deg. round to 140deg, all other directions looking into variously rising ground/obstructions. We were using our club call **GB5FI**.

The results were as follows:

**July 24th.** Dry, overcast.

1800 GB3CCX S9 Steady signal. Line of sight. 97km.

**July 25th.** Showers, windy.

Attempted contacts with G3FYX, IO81RM and G4ALY, IO70VL, both unsuccessful. Later worked Roy, G3FYX via rain scatter 595/555. 1640 GB3CCX S9+5 Steady.

**July 26th.** Clear dawn, then continuous rain.

0520 GB3CCX S9 Steady.

0625 GB3CCX S5 to S9 note.

One way with G4UVZ 59@150deg. and also via a reflection off Penarth Head @350deg. Rain scatter.

1200 GB3KBQ S1 steadily rising to S5 over about 3 hours, rain scatter note, antenna heading into buildings/steeply rising ground.

1750 GB3CCX S5 RS note.

**July 27th.** Sunshine, light breeze. Equipment soon dries out! 2 way contacts with:

G4EAT 519/509 JO01HR.

G3JMY 59/59 IO81RM.

GW8AWM/P 59+/59+ IO81NV.

GW3ATM/P 59/59 IO81LS.

1 way from:

G4RFR/P 51 IO80UU reflection via Penarth Head.

G8OHM/P 55 IO82QL.

ON1CFX/P heard on 2m but not on 3cm.

GB3ANG heard on 2m at S5 throughout, with very little variation in strength whatever the beam heading! No GMs despite my calls.

We found this a very interesting weekend of operating. Much was learnt, about propagation and the short comings of my equipment! Many thanks to all those who turned out to make it possible.

**Keith, GW3TKH**

**From: Steve Cooke, G1MPW**

[[scooke@tiscali.co.uk](mailto:scooke@tiscali.co.uk)]

Steve GIMPW and Dave G6KIE were on Firlie Beacon, JO00BU, for the August 5.7/10GHz contest. They had a good day -- 15 contacts for the best points total so far and 4 new squares as well! The best DX of the day was G3PHO/P (IO94MI) at 396Km which was also the best DX yet.

**From: Ralph Bird, G4ALY Cornwall, IO70VL**

[[Ralph.Bird@btinternet.com](mailto:Ralph.Bird@btinternet.com)]

**Sent: 29 August 2003**

I am now qrv on 13cm.

I put it on the mast this afternoon (29 August) and had the first qso this evening at 2044z with GORRJ both on cw and ssb. 519/529.

I am running 20 watts to a Wimo 67el yagi at 35ft. The transverter and PA in a box up the mast. a piece of superflex 3m long from box to aerial feed point.

This year things have been going very well here from home station. It started May 18th. with F6APE Wrkd 70/23/6/3cm at 436.1k. F6DKW 3cm 499km.. June F6DWG/P 3cm at 462.6km. F1PYR 3/6cm at 479km, F6DWG/P 6cm 462.6km, F5HRY 6cm 514.0km, F1BZG 3/6cm 524.1km, F1HDF/P 3cm 548.4km...July PA6NL

23cm 602.8km. F6KCP/P 6cm 548.4km. .. Aug 8th..  
**E8BXP 70cm 2656.3km.** Aug 8-9th PAOWWM  
70/23/6/3cm 630.3km, 13th Aug (unlucky for some??)  
**F6DRO 3/6cm 902.1km, F1GTX 3/6cm 827.1km,**  
**F6AJW/P 3/6cm 806.3km.** A lot of the above except  
the last 3 have been now worked several times over  
this period. Then it all went very quiet after that  
**73 from Ralph, G4ALY**

**From: Simon Lewis, GM4PLM**  
**[simon@creoch.freeserve.co.uk]**

On Saturday 9 Aug - Nick GM4OGI came to my QTH to help sort out some difficulties on the 3cm equipment that we discovered on the previous cumulative. After a long and hot afternoon outside, we discovered that the WG16/N transition was not working well and that swapping it for another vastly improved things. Now we could hear cold sky/warm building noise differences. Nick's DB6NT beacon sender, terminated in a 50 ohm load and sitting on the back seat of his car, was audible over 3 miles away very strongly when he took his small beacon for a drive round my local area! The icing on the cake came in the evening, after dinner. Cloud had been building quickly during the afternoon and by 2100 we had a few drops of rain from a very dark and overcast sky. I had asked Mark GM4ISM to put a signal up on 10GHz, from his home QTH to us, around 60 km away over a VERY obstructed path. At first we couldn't hear him and we moved up the hill by the farm to some clearer ground. Trying first on open waveguide, we heard him at 52 but with a very rough carrier. Adding a small 60cm dish to the Chapparral feed held by Nick we heard Mark at 58RS easily. Nick's circus act of positioning the feed by hand whilst balancing the dish on his knee was very funny to see, especially as we had around 50 young heifers in a field opposite watching intently at our game show antics! Lucky this is a quiet back road! Nick and I started to swing the dish round and noticed that Mark was audible over around 120 degrees with auroral like roughness. There was some heavy rain at that path somewhere! Quickly moving back down the hill to my house we swung my 1.2m dish into line and elevated it by about 10 degrees. Calling Mark on the mobile again I asked him for a carrier on 3cm. WALLOP! 59+ + + + with massive scatter on his signal - again audible over 120 or more degrees. A two way QSO on CW and SSB was made before the rain started to hammer down from the black skies. .... quite a dramatic demonstration of rainscatter on 3cm and a fine end to an interesting day. We reckon we improved receiver capability on 3cm by a minimum of 20dB. So look out on the next cumulative! Of course a better match on the transition will also improve TX performance.

**From: Mike, G0JMI [mike.karen1@tesco.net]**  
**Re: 5.7/10GHz contest: Sunday 27th July,**

I was only able to operate from 10.30am to 1.00pm on Sunday 27th July due to family commitments but did manage the following QSOs "direct" from my QTH

(I091MD) and not apparently through Rain Scatter from my urban location using the Flyswatter antenna: Stations Worked:

G4ZXO/P at I090WV at 5/9 rx, 5/9 tx. (SSB)

G4NNS at I091FF at 5/7 rx, 5/7 tx. (SSB)

G3LTF at I091GG at 5/5 rx, 5/5 tx. (SSB)

G0RRJ at I091FE at 5/6 rx, 5/7 tx. (SSB)

G8BKE/P at I080WP at 5/4 rx, 2/1 tx. (SSB and CW QSO)

G8OHM/P at I082QL at 5/2 rx, 5/2 tx. (SSB)

The QSO with Frank, G8OHM/P, being at close to 190km - my second longest ever from my QTH I091MD and certainly the furthest using the "direct" path! (Thanks Frank).

On Monday evening (28th July 2003), we had a 3cm group work via rain which was rather surreal and was rather like 2m! This was using SSB with G4NNS, G8GTZ and G1JRU (all also home located) and myself at 5/9+ for a period of about 30 minutes during the rain storm around 10pm (great fun). **73 from Mike, G0JMI.**

**From: Peter Blakeborough, G3PYB, (Portsmouth)**  
**[peter@papine.demon.co.uk]**

**Subject: Cumulative Contest: 27th July**

G3PYB/P operated from Portsdown Hill I090 LU with 3W to a 60cm offset and 3.5W on 6cm to a 98cm offset dish. Weather was good if windy at times with excellent visibility over the Solent. Best Dx to the South was F6APE at 408 km IN97QE on both bands, 6cm gave the better signal, and PHO to the North at 276km in I093EH. No other French stations were heard, which is unusual as F6APE was excellent copy from below Nantes. Conditions were relatively poor overall, with difficult 2mtr talk back at times, a new station worked was G8GTZ. The larger 95cm dish was made ready for this contest on 6cm and significantly better reports resulted.

**From: Brian. G4NNS (Andover)**  
**[BrianColeman@compuserve.com]**

**Sent: 11 September 2003 18:38**

**Subject 24GHz EME**

With help from John G8ACE, Ian G8CPJ and others I did try to listen in to the various tests on 24GHz EME between Josef OK1UWA, Barry VE4MA and AI W5LUA but unfortunately I was not back in time for their first skeds as I was in hospital overnight after minor surgery. I was on in time for some later skeds but heard nothing. **(Success later! See Nov newsletter .. editor)**

The system is giving 11dB of sun noise and 1 dB of moon noise but the LO was a bit suspect at the time introducing a very warbly note according to my marker and this together with the spread nature of the 24GHz echoes could have been enough to explain the failure. I am now playing with a rather nice professional synthesiser (on loan) and John is looking at the original oscillator so we should sort that problem out in time for the next tests (if any). **73, Brian G4NNS**

**MORE ACTIVITY NEWS NEXT MONTH ..**

# ALL TIME SQUARES/DX LADDER

Entries ranked on squares. In cases of a tie the countries score determines the final order.  
 Entries must be from defined locations. An asterisk (\*) denotes UK record.

BAND	CALL	LOC	SO	COUNTRIES	DX	BAND	CALL	LOC	SO	COUNTRIES	DX	BAND	CALL	LOC	SO	COUNTRIES	DX	
1.8GHz	G3XDY	JO2OB	137	24	1341	G3WVG	IO2RG	IO2PA	55	16	1135	47GHz	G4DKK	IO2PA	7	3	266	
	G4DDK	JO2PA	73	16	1005	G4BRK	IO2DP	IO2YMP	53	13	1115		G3WDM	IO2CA	6	2	182	
	G8VOIP	IO2MX	66	18	1134	G4KGC	IO2RG	IO2RG	52	15	1135		G3WDG	IO2RG	5	2	*391	
	G8RRL	IO2FE	56	15	1174	G3XDY	IO2OB	IO2AD	52	13	1012		G3PHOP	IO2AD	5	2	139	
	G4EAT	JO1HR	48	11	1394	G4EAT	JO1HR	IO2JG	52	12	958		G3FYXP	IO2JG	5	1	141	
	G8VHI	?	?	?	1087	G4FCD	IO1HX	IO2JG	47	13	1082		F1GHBP	IO2JG	4	2	158	
	G8DKK	IO1VX	32	10	797	G4DDK	IO2PA	IO2TD	42	12	1012		G4KZNP	IO2TD	3	2	173	
	G6XDI	IO1SM	30	8	945	G3FYXP	IO1GI	IO1HX	35	10	787		G4FCD	IO1HX	3	1	154	
	F1VBW	JO2SO	22	4	825	F1HDFP	JN19GF	IO1HX	34	11	*1275		G8VOIP	IO1MX	3	1	88	
	G4LDR	IO1EC	22	6	593	G3GNR	IO7WT	IO1AQ	34	11	753		G3GNP	IO1AQ	2	2	154	
	G8FYX	IO1RM	21	8	1166	G8VOIP	IO1EC	IO1AQ	32	8	1118		G3GNP	IO1AQ	2	1	81	
	G8AFI	IO8VX	21	8	587	G4LDR	IO1EC	IO1VX	32	8	1118		G8VHI	IO1VX	1	1	100	
	G8WLLP	IO8NR	11	3	620	G3FYX	IO1RM	IO1VX	30	10	1026		G8VHI	IO1VX	1	1	100	
	G8VPU	IO8VX	8	3	299	G8APZ	JO1DO	IO1VX	30	10	1026		G8VHI	IO1VX	1	1	100	
	2.3GHz	G3XDY	JO2OB	54	12	1179	G3JMY	IO1RM	IO1VX	25	8	1137		G3FYXP	IO1VX	4	1	136
G4DDK		JO2PA	28	6	1005	G4BCHP	IO1JO	IO1VX	25	7	1177		G4KZNP	IO1VX	2	1	117	
G8RRL		IO1FE	20	6	1174	G3PHOP	IO3EH	IO1VX	24	8	586		G3UYNP	IO1VX	2	1	65	
G8VOIP		IO6MX	18	6	770	G3UYNP	IO3XA	IO1VX	22	6	522		G3UYNP	IO1VX	2	1	78	
F1VBW		JN6SO	18	1	825	G8RRL	IO1FE	IO1VX	22	5	443		G4DDK	IO1VX	1	1	39	
G4LDR		IO1EC	10	2	444	G3JMBP	IO9TV	IO1VX	20	6	578		G4DDK	IO1VX	1	1	39	
G3FYX		IO1RM	8	2	521	G8LSDP	IO9TV	IO1VX	20	5	384		G4DDK	IO1VX	1	1	39	
G8XDI		IO1SM	6	1	183	G8LSDP	IO9TV	IO1VX	20	5	489		G4DDK	IO1VX	1	1	39	
G8DKK		IO1VX	6	1	174	F1GHBP	IO8XS	IO1VX	19	3	431		G4DDK	IO1VX	1	1	39	
G8VPU		IO1VX	3	1	82	G8DKK	IO8XS	IO1VX	18	6	578		G4DDK	IO1VX	1	1	39	
G8KEP		IO6RQ	3	1	114	G4KNZ	IO1PU	IO1VX	17	6	1052		G4DDK	IO1VX	1	1	39	
3.4GHz		G3XDY	JO2OB	18	5	980	G8LSDP	IO8WP	IO1VX	16	4	385		G4DDK	IO1VX	1	1	39
		G4DDK	JO2PA	9	5	754	G3JMBP	JO1BB	IO1VX	16	4	368		G4DDK	IO1VX	1	1	39
		G3PHOP	IO3EH	9	2	275	G8LSDP	JO1BB	IO1VX	16	3	368		G4DDK	IO1VX	1	1	39
		G8VOIP	IO6MX	8	1	214	G4MAP	IO1WJ	IO1VX	16	3	309		G4DDK	IO1VX	1	1	39
	G3FYX	IO1RM	4	3	487	G3UKV	IO2RR	IO1VX	15	7	494		G4DDK	IO1VX	1	1	39	
	G3FYXP	IO1GI	2	1	92	G4JNT	IO9VJ	IO1VX	14	4	339		G4DDK	IO1VX	1	1	39	
	G8KEP	IO6RQ	1	1	114	G4RRP	IO8UJ	IO1VX	14	4	414		G4DDK	IO1VX	1	1	39	
	G8VPU	IO1AX	1	1	19	G3ZMEP	IO2QL	IO1VX	13	4	357		G4DDK	IO1VX	1	1	39	
	5.7GHz	G3XDY	JO2OB	26	7	947	F1VBW	JN6SO	IO1VX	13	1	665		G4DDK	IO1VX	1	1	39
		G8VOIP	IO6MX	17	5	730	G4MAP	IO2JG	IO1VX	11	3	311		G4DDK	IO1VX	1	1	39
		F1GHBP	IO8IN	12	4	436	G8VHI	IO8XG	IO1VX	10	3	304		G4DDK	IO1VX	1	1	39
		G4LDR	IO1EC	11	3	436	G3PHO	IO8XG	IO1VX	8	3	748		G4DDK	IO1VX	1	1	39
		G3PHOP	IO3EH	7	2	507	G8VHI	IO8UJ	IO1VX	8	2	277		G4DDK	IO1VX	1	1	39
		G3PHOP	IO3AD	7	2	227	G8VHI	IO8UJ	IO1VX	7	3	415		G4DDK	IO1VX	1	1	39
		F1VBW	JN6SO	7	1	665	G8VHI	IO8UJ	IO1VX	7	2	248		G4DDK	IO1VX	1	1	39
G8FYXP		IO1GI	6	2	335	G8VHI	IO8UJ	IO1VX	6	2	323		G4DDK	IO1VX	1	1	39	
G3PHOP		IO3FB	5	2	426	G8VHI	IO8UJ	IO1VX	6	2	273		G4DDK	IO1VX	1	1	39	
G4DDK		JO2PA	3	3	233	G8VHI	IO8UJ	IO1VX	5	3	279		G4DDK	IO1VX	1	1	39	
G8VPU		IO1AX	3	1	124	G8VHI	IO8UJ	IO1VX	4	2	242		G4DDK	IO1VX	1	1	39	
G8KEP		IO6RQ	2	2	242	G8VHI	IO8UJ	IO1VX	4	1	87		G4DDK	IO1VX	1	1	39	