

MICROWAVE NEWSLETTER



An Amateur Radio publication for the Microwave enthusiast, published by the Radio Society of Great Britain and edited by G3PHO and G8AGN

Lambda House, Cranborne
Road, Potters Bar,
Hertfordshire, EN6 3JE

FROM THE EDITORS

April 1994

The Easter week proved to be a big disappointment weather-wise! We hope you managed to get some microwaving done however. The home stations will have made good use of the rainscatter (lots of good showers that week) but you portable types would certainly have felt the wind....write in and let us know what you have been working recently. Remember, there are **other bands** than 10GHz!

WE ARE GETTING CONFUSED!

The November 1993 Newsletter published a telephone number for Telford Electronics Distributors. This was a correction to a previous number and was sent in by a reader who had purchased items from that business. We now have a further correction for you! This should be 100% correct as it comes on a T.E.D official letterhead so PLEASE ring this number in future as the people who own the number published in November are getting rather fed-up with calls from microwave amateurs!

THE CORRECT TEL. NO IS: 0952 605451

FOR SALE

G8CHW has the following items for sale:

13cm SSB Microline 13 Transverter with units SLO13, STM13 and SRM13, complete with 2metre input, relay, etc in a LT23 box. Ex. working order. Ideal for newcomer to 13cm! All paperwork included. **ANY REASONABLE PRICE TAKEN!**

Wideband 3cm TX/RX, complete with Solfan head. Wkg but have not had a QSO with it. All paperwork and leads. **ANY REASONABLE OFFER ACCEPTED.**

FOR SALE (continued)

BXY28 srd trebler, metal work only. Designed by G3KFD/G8GDZ and made by the late G3VVB. 1104/3312MHz or 1152/3456MHz. All paperwork included. **ANY REASONABLE OFFER ACCEPTED.**

SSB transmit mixer for 3456MHz (DC9XG - VHF Comms 1/84). Input 144MHz. Built by G3VVB. Metalwork only. All paperwork inc. **ANY REASONABLE OFFER!**

3456 filter, with information. **ANY REASONABLE OFFER SECURES!**

WRITE TO G8CHW, C.R. Tredwell, Flat 3, 177 College Road, Moseley, Birmingham B13 9LJ.

MARTIN, G3ZQU (tel. 0449 711367), "Cedars", Church Lane, Stonham Parva, Stowmarket, Suffolk, has the following items FOR SALE:

Miniature SMA 2 watt fixed attenuators, 3, 6, 10 & 20dB, all **£10 each.**

HP140T + 8552A Spectrum Analyser, c/w all handbooks, plus tracking generator and preselector. All wkg. Price **£800**

Double balanced mixers, WJ M14. LO 4-9GHz, RF 4-8GHz, IF dc-2GHz, +7LO. Several available at **£25 each.**

Variable stepped attenuators: SMA 0/70dB in 10dB steps price **£25**. BNC 0/1dB, in 0.1dB steps. Price **£15**. BNC 0/70dB in 10dB steps. Price **£20**.

Various miniature SMA isolators, splitters and couplers. 4, 6, 10 & 12 GHz. Most with HP8510 plots. **PHONE FOR DETAILS. All at £10 each.**

Various SMA connectors, joiners each at **£2.50**

SMA microstrip launchers, new at **£5 each.**

RSGB Microwave Committee Update

A brief summary of the recent meeting held on the 5th March 94.

The VHF convention was reviewed, and the possibility of a microwave specialist meeting in the morning raised for 1995. The stand was better than last year (but could still be improved), and the earlier date better.

Some time was spent discussing databases, and a list of those that would be useful. G0CZD had already made much progress with a bibliography, with others such as a suppliers list to follow. These would be available either as a compiled PC program, or ASCII text, or on printed paper. Also a newsletter questionnaire to update the operators directory was planned.

Bandplanning - work is ongoing to look at the format of bandplans, and a draft considered. The problem is that those currently printed (eg in Call Book) combine the bandplanning with licensing information, and leave little space for UK usage.

Beacons and repeaters:- GB3KBQ (10368.870) became operational on 1/Dec/93; GB3LEF (3.4) is now licensed but not yet operational; GB3WC (Wakefield 23cm repeater) applying for horizontal polarization. No news yet on 10GHz narrowband beacons near London.

Contests and activity was briefly discussed, after several comments re lower band cumulatives, and monthly mid-week activity days. This needs to be considered properly.

Some other points in brief: technical development covered in last month's NL; software library material passed to G4ASR; some material collected for planned artwork library; 2 papers completed for Region 3 conference by G3PFR (on DSI and CEPT).

Info Available

A table of the 1993 IARU R1 Conference Decisions (Microwave Papers only) is available. This tries to summarize what happened to each paper, all on one page, since the minutes contain much more, and the fate is not always clear.

Also available, a list of "Microwave Designs" for bands other than 10GHz. It stems from the committee technical discussions (there is not space right now to include it in the newsletter, since it takes over 2 pages).

Also available, a 'Microwave Cumulative Logsheet', as produced by G8KMH and available at Sandown, as an alternative to the standard VHF sheet. It includes space for different sites (most useful for 24GHz). For the 10/24GHz cumulatives only (not other RSGB contests).

Comments should be addressed to Steve Davies G4KNZ (Chairman) at 14 Herondale, Birch Hill, Bracknell, Berks. RG12 7ZT. For a copy of any of the info items, send an SAE to G4KNZ.

Wireless LANs

Those in the computer business will be noticing Wireless LAN (local area networks) hardware starting to appear in the trade press. Right now costs are not cheap, eg £800 per PC or workstation, but they are coming down.

In the UK, an interim regulation MPT1349 allows these in a 30MHz band from 2445 to 2475MHz, maximum 1W output. A European standard is likely to supercede this soon, giving a band from 2400 to 2483.5MHz, but with 100mW maximum output.

The signals are spread spectrum, spread out over the band. It would be interesting to have some measurements of noise levels close to a large installation, to see if there is a noticeable increase.

US Microwave Standings

Like our squares table, QST publishes a 'Microwave Standings' table at the end of each year. These are all-time listings, and some highlights (to end 93) are:

On 3cm, 17 entries listed, best is W6HCC, with 34 grids (squares), and best (terrestrial) DX of 864km. (Cf G3WDG with 30sq/1008km). On 12.5mm, 5 entries listed, best no squares 5 (W6CPL and N6CA), and best DX 201km (N6OLD/P). On 5cm, 13 entries (ie nearly as many as 3cm), best N6CA with 15 squares and DX of 3974km.

See January 94 QST for full details.

MODIFYING THE G4DDK004 SOURCE BOARD FOR THE BFG91A

by Mike Walters, G3JVL

When I first constructed this module I followed the procedure and used the devices described in the RadCom article of August 1990 My required output frequency was 2404/3MHz and I obtained a good, power output of 5mW. Having read comments on using the BFG91A I decided to try using them myself and, sure enough as reported by Sam (G4DDK), the stability was poor. However I persisted with the following modifications until a stable unit was achieved and ended up with a most useful source providing around 50 milliwatts of very stable output. In order to understand the following comments it is essential to have the full circuit diagram and pcb layout at hand.

The first modification was to replace the ground plane above and around TR5, as this is a vital area. The decoupling capacitors, throughout the p.c. board, were replaced with 100pF ATC chip types, size "a", available from Mainline of Leicester. These need to be as close as possible to the transistor body and very little filing was needed to open the ready-cut slot ends to the right size...approximately 1.6mm. The chip cap can then be fitted by bridging with solder to the emitter track and the ground plane respectively.

Some copper tape is cut to cover the triangular shape of cut-outs on the ground plane side around TR5 and soldered in place. I have tried R17 and R18 with very small clearance around their base ends on the original side of the board and also the same components on the track side, or replaced with surface mount resistors on the same track (without any holes on the GP side). All behaved very similarly, so choose what best suits you!

The other addition is a stub at the collector of TR5. This might need trimming for different output frequencies. The stub dimensions are: 2.5mm width and a total length of 20mm (adhesive copper tape) off-set with respect to the collector lead (see diagram below).

I did the same modification to the previous stage, with less dramatic effect due to the frequency...i.e. the cut-out at 2.5GHz is much bigger in wavelength terms. After retuning and stub trimming a few times, my final result was, with both TR4 and TR5 changed to BFG91A devices, some 50 mW of clean, stable output.

If you try these mods, please report your success (or lack of it!) to the Newsletter.

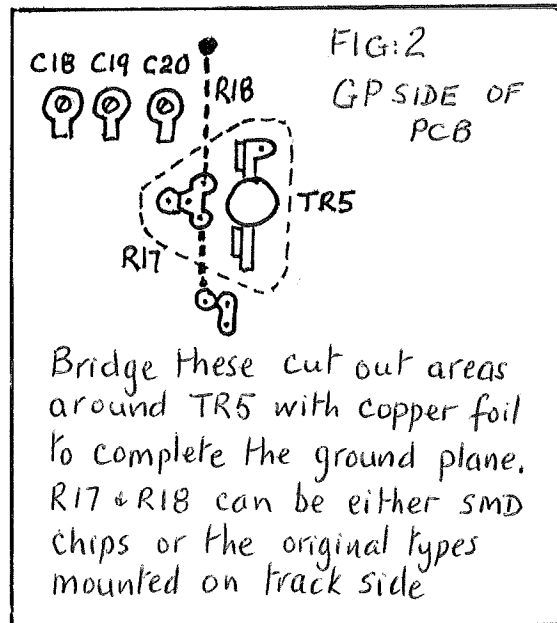
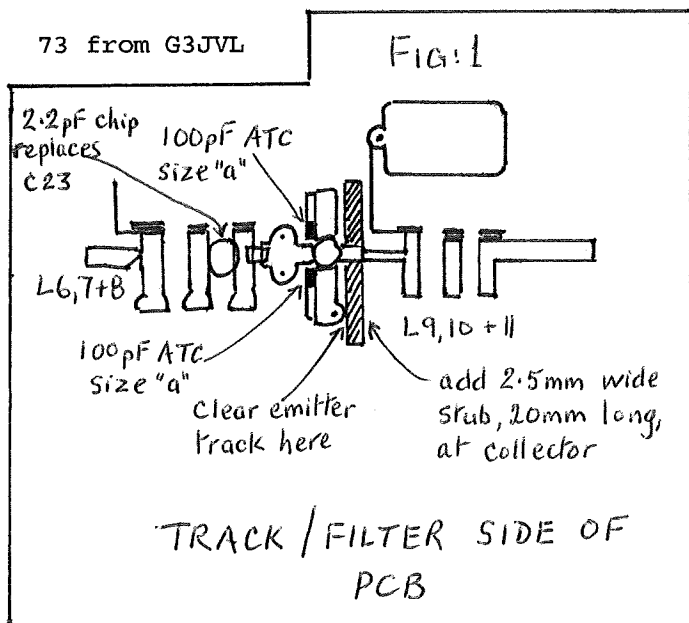

Blue Cap LNBS reused

- BY GW4JJW

Examination of some LNB boards obtained at a southern Microwave Round Table revealed that it is possible to re-use parts of the circuit board as an 11.75GHz amplifier. In addition, if the bias arrangements on the board are changed it can also operate (albeit not very efficiently) at 23.5GHz. An 11.75GHz to 23.5GHz multiplier has been developed. At 23.5GHz the existing matching arrangements for the GASFET devices are useless and should be totally removed. The LNB board is far from optimal at 23.5GHz as it has a high radiation loss. As the sections of the board used are untuned it should operate at 24GHz.

11.75GHz Amplifier

The design frequency of the LNB is roughly 11GHz and therefore not much modification is required. Holding the PCB with the patch antenna, located under the horn, at the top right hand corner of the PCB, the two stages to the right of the edge coupled filter, roughly in the centre of the board, were used.

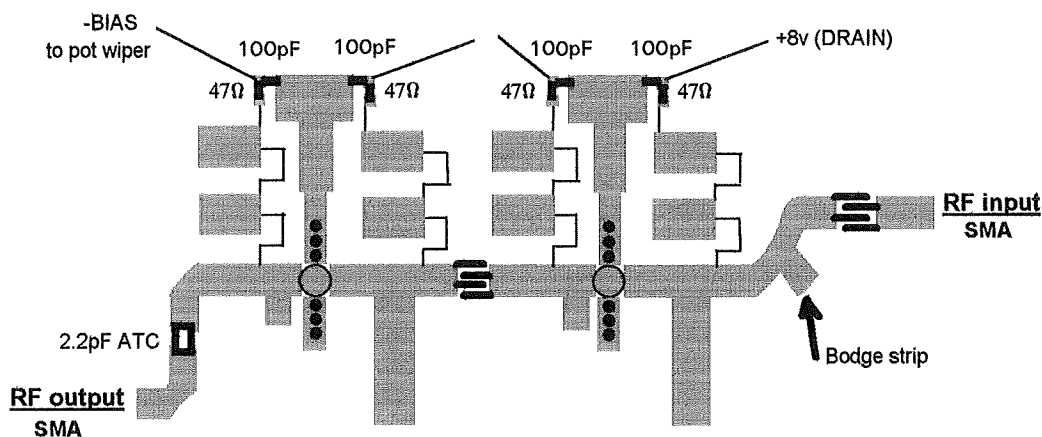

Two stage 11.75 GHz amplifier

A 2.2pF ATC capacitor was placed in the 50Ω output line (that previously went to the filter). 0805 Chip resistors, of value 47Ω, were used in the gate and drain circuits as per WDG001 and the cold ends of these were decoupled to ground with 0805 100pF chip capacitors. Suitable PCB pads exist for these components. Two

Birkett black-spot devices were used in the amplifier. Fine wires were used to feed the various voltages to their input point which are the junctions of the 47Ω resistors and 100pF capacitors.

On the original LNB the outputs of the two preamplifiers, one for each polarisation, are combined by a Y junction with a Lange filter in both the upper arms. One of these couplers is totally removed using a scalpel to give a smooth 50Ω profile. An SMA connector is soldered to the 50Ω track leading to the remaining one.

The board was mounted in a cut down tin-plate box type 7754 and SMA connectors used for input and output RF connections. The final size of the box was 56.5mm x 34.5mm x 27.5mm deep. A conventional 8V G4FRE bias supply was used for the GasFETS with a suitable value chosen for R1 (4K7). Two 10K preset pots were used to control the gate voltages. These were mounted on veroboard on the ground plain side of the PCB together with the G4FRE bias supply. The performance obtained was:-

Comment	Power in	Power out	Gain
without matching	2.8mW	32mW	10.58dB
output matched*	2.8mW	40mW	11.55dB
output matched*	0.34mW	21mW	17.90dB

*output matched indicates the bodge strip was installed.

The amplifier was almost certainly saturating during the first two measurements but it was thought worthwhile to include the results anyway.

11.75 to 23.5GHz Multiplier

Although radiation losses from the PCB will be high this design provided a usable amount of RF at 23.5GHz quickly and cheaply. A single stage from the LNB is utilised but the bias arrangements must be heavily modified to work at 23.5GHz. The key to the modification is the reconstruction of the high and low impedance bias lines.

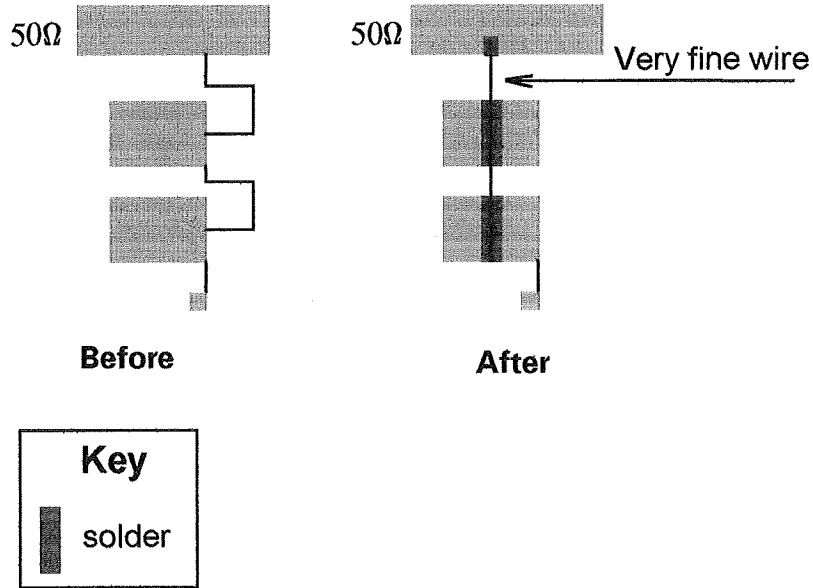

New Bias arrangements for 23.5GHz

The multiplier is made from the pre-amplifier section of the PCB which is in the bottom left hand corner if the horn patch antenna is in the top right, although other portions of the board could be used. A piece of thin brass sheet is cut slightly larger than the size of the fragment of LNB. The actual size is defined by the size of the board cut and whether the plate will occupy the full waveguide width. A sliding short circuit for WG20 is created. A 0.6mm diameter hole is drilled through the PCB at the output end of the 50Ω track, almost at the very end of the track. The centre of this hole is then transferred to the brass plate. The hole is then drilled through the brass sheet such that UT085 coax (or similar) is a push fit. The brass plate is silver soldered to the broad face of the waveguide such that the hole lies in the centre of the broad face. The hole is then continued through the waveguide face.

The coax is prepared thus:-

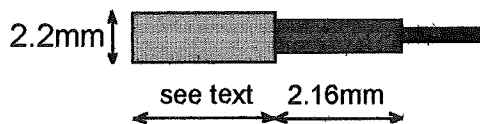

The length of exposed dielectric is equal to half the waveguide height. The length of the copper outer is equal to the thickness of the brass plate plus waveguide wall thickness plus allowance for silver soldered joint. If this is made very slightly over length excess can be removed with a fine file later. The exposed inner of

the coax will later be pushed back up through the coax and protrude the other end where it will engage the circuit board.

The coax is then installed in the hole and carefully positioned so that the coax outer does not penetrate the waveguide and the inner does not touch the bottom. Ideally the coax should be a push-fit in the hole. The coax is soft soldered in and the brass plate also tinned with solder at the same time. Excess solder is wiped from the brass plate. The inner of the coax is then pushed up so that it is flush with the dielectric on the inside of the waveguide. Excess outer is now carefully removed using a fine file taking care not to damage the inner conductor.

The copper ground plane is removed in the vicinity of the 0.6mm hole, using a burr, to about the same diameter as the coax. The ground plane of the PCB is then lightly tinned with solder.

The PCB is located on the inner of the coax and rotated such that the 11.75GHz input is at the edge of the brass plate ready to take the SMA. The whole assembly is heated through an aluminium plate and the board pressed down on the plate while the solder solidifies. A steel weight is useful here. The centre of the coax is then soldered to the 50 Ω track and an ohm meter used to check for a short!

The inner of a two hole SMA socket is soldered to the 50 Ω track and the body is soldered to the brass sheet. During this operation it may be useful to keep the waveguide cool with a wet tissue.

A section is cut from the input side of the 50 Ω track and a 2.2pF ATC chip capacitor is inserted.

The bias arrangements for the 23.5GHz side of the multiplier are modified as described above.

The existing matching stubs are removed from the 50 Ω line using a sharp scalpel.

The components are mounted on the board and a suitable bias and drain supply is provided. The author used a red-spot device, +8V drain supply and a 10K Ω preset potentiometer adjusted bias supply. A G4FRE PCB was used as a PSU, the value of R1 being 10K Ω .

New matching strips are placed on the board to achieve maximum power out at 23.5GHz. There is a need to ensure that only 23.5GHz power is monitored and not the 11.75GHz fundamental or higher harmonics when optimising power output by installing bodge strips.

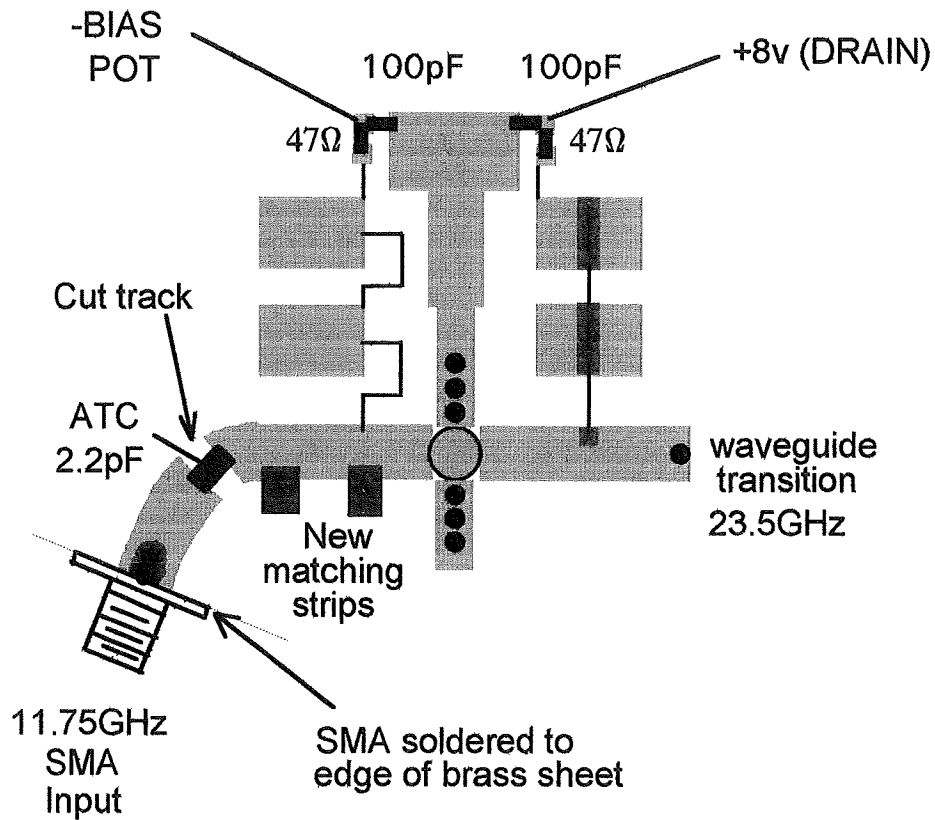

The finished multiplier PCB layout

The Following table summarises the performance of the multiplier.

11.75GHz power	Power before filtering	23.5GHz power after a matched 2-pole post filter
45mW	9mW	4mW

A REMOTE CONTROLLED WAVEGUIDE SWITCH

by John Tye, G4BYV

The diagrams that follow should allow anyone to reproduce this switching arrangement provided a suitable 12 volt dc motor can be obtained. The one I used originally worked a crystal turret on an aircraft transmitter. The switch can be mounted in the same case as, say, a complete 10GHz transverter which is then mast-mounted as close to the dish as possible, thus keeping feeder losses to a minimum. The whole thing runs off 12 volts.

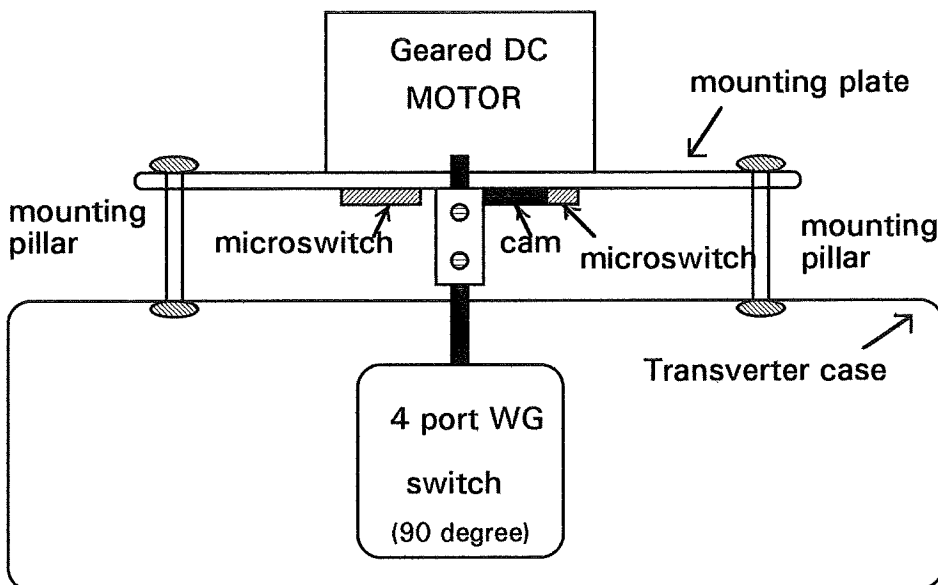
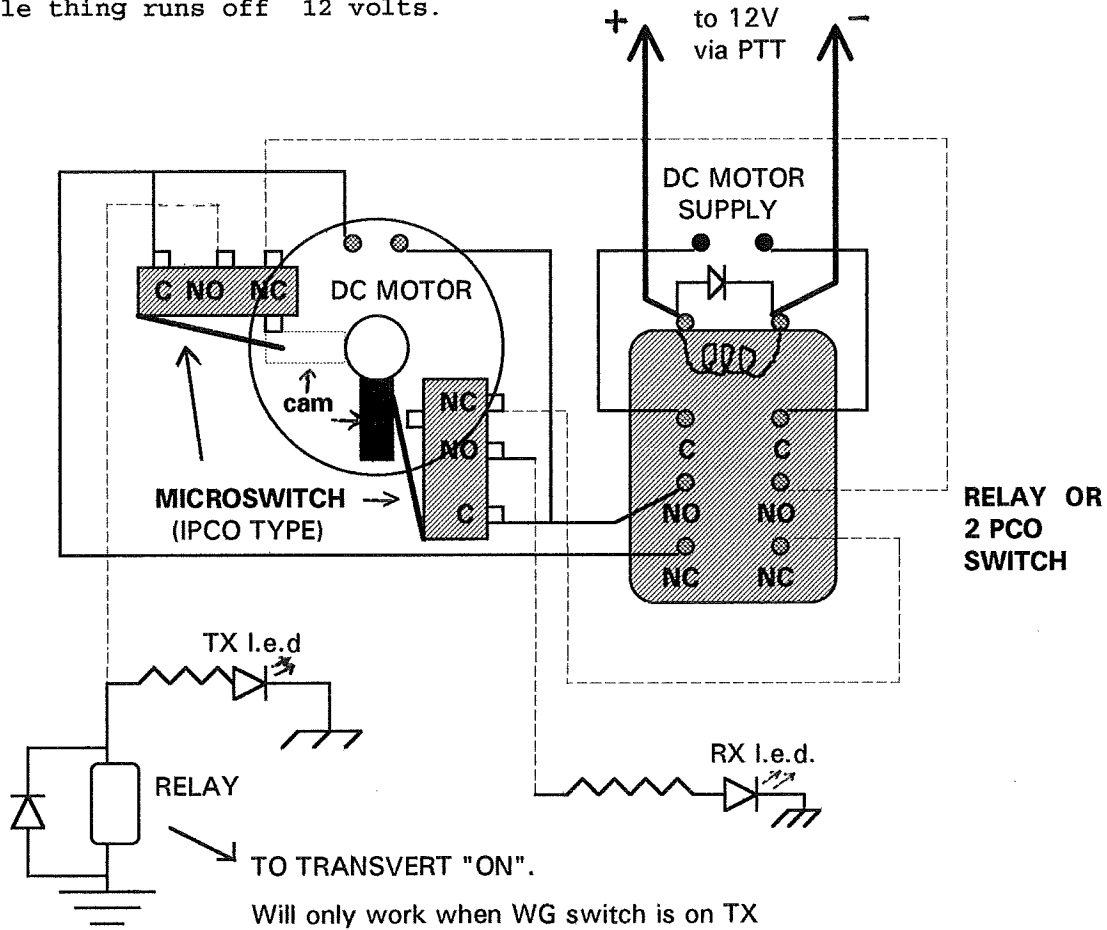

ACTIVITY NEWS

NEWS AND VIEWS FROM THE WORLD ABOVE 1000MHZ

The Winter Cumulatives seem to have been very popular this year with a great deal of activity, sometimes rivalling the summer events. Out-of-contest operation has also been good, particularly on the 10GHz band, to which most of the following reports relate.

Steve, G1MPW (Croydon) operated from Exmoor on Boxing Day and found the weather bright but cold. He made 2 x two-way and 5 x one-way QSOs, the best being with G4KGC (Rushden, Northants) at 240km. Sadly Petra could not hear Steve's 30mW. On 27.3.94 he was portable at Tatsfield (IO91XH) and "bagged" 14 stations in 5 squares, the best score to date, including G8s UYR/P and SWZ/P at Titterstone Clee (215km). Steve attended the Southern Round Table at RAL and was quite staggered to find that a supposed SMA joiner was in fact a 3dB pad!!!! It was a stainless steel device, with no markings on it. On removing it from the gear, Steve's RX noise figure improved by 3dB and the power out on TX doubled! Perhaps readers might like to check their gear if they have inexplicably low output from some of their 10GHz modules!

Ted, G3JMY of Bristol, has recently worked his all-time best DX on 10GHz from the home location, Viz G4LOJ at 290km. It was a rain scatter enhancement that just brought signals above the noise level. Together with some extra stations worked this year, this doubled his Operating Ladder score! Ted runs 8 watts on 10GHz to an 18 inch diameter dish at 30 feet agl. His RX system noise figure is 2.5dB. During some very gusty weather this winter Ted had an unusual problem with his antenna. The vibrations on a 23 inch dish caused the broad faces of the WG16 feed to "wrinkle" at the top and bottom ends. The wrinkles were up to 0.05 inches deep and appeared to produce a mismatch. A close-fitting brass plug and a small pein hammer were used to remove the wrinkles and the guide has subsequently been stiffened. The 23" dish has been replaced with the 18" one and all is now back to normal. Ted reports home to home contacts on a regular basis with G3GNR

(Devon) and G8SWZ, G8UYR and G4MAP in the Midlands.

Doug, G3ATM (Ilfracombe), has blown up the TX output transistor in his "White Box" (MACOM) 10GHz rig. A replacement device only produces 100mW so he is saving up for a WDG007 1 watt amplifier kit! On 27 March he operated /P from the Bloreng, near Abergavenny in South Wales, but the windy and wet weather made him retreat after only a couple of contacts or so.....G4BRK and G4KGC (181km). A very amusing incident occurred that day....there was a Fell Running race over the Bloreng. Doug had his microwave gear set up by one of the race check points and as three runners came past him they shouted their numbers, 77 74 72, into his dish antenna!!

From Devon we hear from **Bill, G6XM (Okehampton)**. He is making a 24GHz narrowband system but is having a few problems getting sufficient local oscillator drive. Bill has also disposed of his "White Box" in favour of a WDG system which he has recently completed. A photograph sent to your scribe shows this new system looking into a Philips fluorescent lamp which is used as a noise source, providing some 5dB of noise in fact! A 20 watt Osram lamp of similar type gives 8 or 9dB of noise. According to Bill, setting up on noise is much better than trying to peak everything up on his local beacon. He notes, "with dismay", that the June Microwave Cumulative Contest clashes with the Longleat Rally and, since this is the premier rally of the season, he will not be active in the contest unless he can arrange something on the way home from the rally. (*Editors note: The Committee realises that these clashes will happen. There are just not enough free Sundays in the Summer when clashes can be avoided...we now have established a pattern of having the 10GHz contests on the LAST SUNDAY of the month...rally organisers please note!*). Look out for Bill this summer. He is well located to provide many with their best inter-G DX on the 3cm band.

**1994 OPERATING LADDER
(Ranked on multiplied scores)**

BAND	POS	CALLSIGN	STATIONS WORKED	BEST DX (km)	MULTIPLIED SCORE
10	1	G3JMY	19	290	5510
	2	G3UKV	14	311	4354
	3	G3GRO	13	277	3601
	4	G4BRK	15	156	2340
	5	G4KNZ	12	168	2016
	6	G8DKK	6	143	858
	7	G8KMH	1	135	135
24	1	G4KNZ/P	4	126	504
	2	G8KMH/P	1	126	126

RULES FOR THE OPERATING LADDER

Use only distances (DX) and stations worked during 1994. Stations worked must be **different callsigns**. A callsign is based on the prefix. Thus GW3WDG is classed as a separate call to G3WDG. Fixed and portables count as separate also. Multiply your different calls worked by your best DX of the year so far to produce the multiplied score. Send your entries in at regular intervals if you want to keep your rightful position on the Ladder! You can send in separate

1993-4 WINTER CUMULATIVES

Have you sent in your logs to
G4KNZ yet?

Please do so as soon as possible!

entries for your home and your portable activity if you wish. All microwave bands from 2.3GHz up count. The final table, based on the position as at 31.12.94, will be published early in 1995.

The ALL TIME SQUARES/DX Table has not changed since it was last published in the February 1994 Newsletter. We will update it when you, the readers, send

in new scores as the "season" progresses.

Steve, G4KNZ (Bracknell), has been out and about on 24GHz already this year, as his Ladder entry shows. On the 3rd April he worked a new station on the band, G4CBW. The latter (Tony) operated from his home station near Newcastle-under-Lyme, Staffs., with about 50 milliwatts. This was Tony's first 24GHz contact ever but it will not be his last as the news on the following page will show!

Richard, G3MTG, of Taunton, finds the GB3KBQ beacon (built by G4UVZ) a very good frequency marker in the West Country. It has been within 1kHz of nominal of late on 10368.870MHz.

Richard and Adrian are active on the 10GHz band most evenings and both can give you a frequency check to within 200Hz, referenced to Rugby or Droitwich.

Still on the beacon front we have a request from **Martyn, G3UKV (Telford, Shropshire)** for an up-to-date microwave beacon list. We will try to do this at the earliest possible moment, Martyn. It has been discussed at Committee level and we hope to publish a centre-page, pull out sheet some time in the near future. Thanks, Martyn, for your list of beacons on the 3cm band.

Martyn has been finding 10GHz quite active from his home station. the 2 metre talkback channel (144.175MHz) has been busy most evenings. He has found out why his TWT failed last year (leaving it running for hours/days with just the heaters on). A new TWT is working very nicely. He regularly hears Sam, GI8GJX in IO74AQ. With rain scatter he has had S5 signals from him. Their first QSO took place on 6 March 1994 when Martyn had only 800mW output. A week later they had a full Q5 SSB contact. Apparently Sam has an excellent location, with a clear take-off over the Irish Sea to the east and South East. Finally Martyn pleas for more 23cm activity. He has just upped his power to 20 watts on that band, with a Mitsubishi "brick".

John, G0API (Corfe Mullen, Dorset) has been having some very satisfying results on 10GHz since his mid-93 rebuild. This included a 20 watt mast-head system which enabled him to have a first home-to-home QSO with pal G4JNT, via rain scatter, and a contact with G4UTM, over the hills and far away in Taunton. He has built a Beta-test version of the G4JNT 1.3GHz transverter. It gives 26dB gain with a 4dB noise figure. The G4JNT noise meter is also working well and he has been able to calibrate his rotator using solar noise (with the help of his new PC and VK3UM EME software!). The Sun drives the meter to two-thirds FSD and he can track the Sun over its full arc, up to and including 45 degrees elevation, well above ground noise effects. He thinks he is getting some Lunar noise with his 60cm dish and WDGH HEMT preamplifier. Along with Andy, G4JNT, he is working on a 12 foot

steerable dish at the club station, G4RFR.

MICROWAVE DX-PEDITION NEWS

Tony, G4CBW, has sent us details of his portable expeditions to GM, GW, GD and G during May and June 1994. Two sessions are planned. Each one will essentially be a long weekend and have been timed so that they include two of the narrowband cumulatives contests. The main aim of these expeditions is to operate 3cm TV over previously untried microwave paths, namely the GM/GW and GM/G paths (session 1) and GD to GM/G/GW in session 2.

Tony will initially travel to Scotland (Dumfries and Galloway region, possibly near the Mull of Galloway) and David, G8VZT, will go to Wales to attempt the first GW to GM 3cm TV contact. If this works he will then travel into England to try to work Tony again, for a new TV contact.

The dates are as follows:

SESSION ONE:

GM, GW & G: 25th-31st May 1994

SESSION TWO:

GD, GM, GW & G: 22nd-28th June 1994

Both sessions include microwave cumulative Sundays.

EQUIPMENT: (10GHz)

G4CBW: 2.2W cw/ssb and 1.5W FM TV
1.3dB HEMT + 60cm dish
Possibly 20W TWT(!)

G8VZT: 1W FM TV to a 60cm dish
1.3dB LNB. May be ssb.

Talkback will be via 144.175MHz ssb and/or 144.750MHz FM +/- qrm.

24GHz equipment will also be available!

For further details contact G4CBW, QTHR or tel. 0782 566783 evenings, or Email Compuserve 100064,330

THAT'S IT FOR THIS MONTH...73 de G3PHO