

Microwave Newsletter

Published by the Radio Society of Great Britain
35 Doughty Street, London WC1N 2AE.

Content:- all reports to go direct to the RSGB Microwave Committee. Subscriptions:- to RSGB HQ when requested.
Changes of address:- to RSGB HQ quoting the callsign or reference in the top right hand corner of your address label.

Date:

No.

7.7.81

06-81

Microwave Newsletter 06 - 81 (July)

The newsletter continues to flourish and the circulation list now stands at about 60. Please send operating news, comments, technical items and info to Julian Gannaway, G3YGF, 17 Crick Road, Oxford, or 'phone 0865-59988 ext 348 during the day. The deadline for next month's issue is 3rd August.

Operating News

The third leg of the Cumulative Contest on 21st June at last brought fine weather and plenty of stations were active. Let's hope that wasn't all we'll see of this summer!

G3JHM took his 4' dish to his usual site at Butser Hill, and made 11 two-way QSO's and 2 one-ways. Don reports that no cross-channel QSO's were made, though G3KSU/P heard GB3ALD in the early afternoon. By late afternoon, it had faded out.

Dave, G3YJH, at Titterstone Clee, made 9 two-way contacts, of which 5 were on SSB. Best dx were G8AGN/P, G3PHO/P and G8FWA/P, all over 90km. On the following day, he was able to copy the GB3LEX 10GHz beacon from his home location for the first time. The distance is approx 50km, and the take-off in that direction is poor. Dave has not heard it since, despite listening many times.

G3PHO was on holiday in Derbyshire and "stole away from his family for a couple of hours" to Merryton Low, 5km NE Leek, where G8AGN was also operating. Peter worked G3PFR/P, G8PNL/P, G3MWQ/P, G3ZME/P, G3VZT/P and G3YJH/P, all on wideband fm, and all at about 90km. He also heard GW3YGF/P at 59 from South Wales, trying to work G8AGN/P.

G3PFR operated from Long Mynd with G8PNL and G8XMZ (who was out for the first time). Mike worked G8AGN and G3PHO at Merryton Low (89km), G3MWQ and G3ZME at Brown Clee (27km) and G3FYX at Cleeve Hill (91km) all at 59. G8PNL worked the same, though only had a one-way with G3FYX. G8XMZ made a one-way QSO with G8AGN. Mike also notes paths that didn't work (just as important) : paths to G8AFC on Winter Hill and to G8MWR on Broadway are obstructed, though nevertheless worth trying. G8FWA in Leicester, and GB3LEX were also not heard.

G2DSP had 5½ contacts with G3JVL, G3KSU, G8IDZ, G3JHM, G8MCQ and a one-way with G8GKV (who unfortunately had to retire with gear problems).

G3WDG and G4KGC were at Walbury Hill, Berkshire, and both managed ten or so 10GHz QSO's. Best of all, though was Petra's 5.7GHz QSO with Clive, G4MBS (ex G8ADP) using her scaled version of the G3JVL 10GHz narrowband transverter. The path from Walbury to Clive's QTH is by no means easy, even on 10GHz. Several people, including G4CNV and G3JVL himself are building 5.7GHz versions of the transverter; details will no doubt be published asap. Anyone too impatient to wait, please contact any of the above!

News from Europe - PEIBLE/A heard G3LQR's 10GHz narrowband signal during the good conditions around 8th June.



Other European stations active on 10GHz narrowband include HB9AMH in DG66 square, and DL3ER, who can run 10W to a 1m dish.

Other News

Graham Murchie, G4FSG, has taken over from G3COJ as administrator of microwave beacons. Reports on beacon reception, and correspondence regarding them, should go either to the appropriate beacon-keeper (see "Microwaves", July RadCom) or to Graham at :

7 Grove Gardens
Woodbridge
SUFFOLK
IP12 4LL
Tel: 039 43 4199 (home)
0473 642154 (business)

The provisional date for the next Martlesham Round Table is Sunday 18th October. More details nearer the event, but the usual comprehensive test equipment will be available, plus talks and discussions.

A reminder that the Cheshire/N. Midlands microwave net is still operative, on Thursday evenings, 144.18MHz, A3j, at 21.00 BST. Mike G3PFR reports that activity in this part of the country is on the increase, with G8YEE, G8UYT, G8YHH, G8WHG and others known to be building gear for 10GHz.

G8ZPC and G8XMZ have gear working, and are near to effective operation. Others are interested.

Jim Harris, G4DRV, points out an arithmetic error in G3NAQ's notes on 'the use of reflectors on 10GHz', (Newsletter 01/81). The expanded expression for the received power should read :

$$\frac{W_r}{R_1^2 D^2 + R_1^4 - 2R_1^3 D}$$

* ↗

Equipment for Sale

Steve Birkill, G8AKQ (Sheffield, QTHR, tel: 0742 463259) is moving permanently to the USA on 1st August, and has several items of microwave gear for sale. Of particular interest are 2 large dishes (one 9 foot diameter and complete with ground rotation gear). This dish he has used for TV satellite reception, and it would be very suitable for moonbounce work. Please ring him asap for full details of all gear available.

Dubus-Info

The 4-80 issue of Dubus-Info has just arrived, and the 1-81 issue is apparently on its way. The 4-80 issue includes :

Varactor doubler for 2160MHz by DCØDA (intended for 2C39 power mixer, delivers ~ 2W).

432MHz preamplifier with BFT66, by YU1PKW (1.5dB nf, 14dB gain)

The 23cm "five-minutes-mixer" by DDØQT (simple yet high performance design)

1mW power reference generator by HB9MIN (an HP design, gives accurate 1mW at 50MHz)

A simple microwatt-meter for 1-500MHz by LA8AK (from Technical Topics, September 1980 RadCom)

A scanner for Gunnplexer transceivers, by LA8AK

CW Monitor for IC2Ø2 by YU2REY,

plus all the usual operating news. G3NSM still has one or two spare subscriptions for 1981, at £3.80 for 4 issues. Anyone interested, please contact him at :

26 Charlbury Road,
OXFORD.
OX2 6UU

IC2Ø2's

G4CNV (and others) have tried the front-end modifications suggested in DUBUS-INFO 3-80. The first of these, which consists of bypassing a stage of front-end filtering, is trivial to carry out, and improves the sensitivity by about 3dB. The second modification, which reduces the insertion loss of a filter between rf stage and mixer, is more difficult to implement, and gives much less improvement, so probably isn't worthwhile. Obviously, reducing front-end selectivity has its drawbacks, but in general the strongest off-channel signals to be encountered will be in-band ones, where front end selectivity is no help.

G4CNV suggests a regulator circuit for charging IC2Ø2 nicads (at 200mA constant-current), charging a sealed lead-acid accumulator at 14V, current limited at 1A, and also providing a 13.5V 1A regulated supply for other gear. He has replaced the standard power socket on the IC2Ø2 by one from a TR10 2200 (available from Lowe's) which isolates the nicads when the plug is inserted, and means the nicads can be changed without removing them, while the rig is simultaneously powered by 13.5V from the psu. At the same time, the S0239 socket was replaced by a BNC. All this is perfectly neat and tidy and easy to carry out!

73 de G3YGF, G4CNV and G4KNZ
* * * * *

Late News

G3JHM will be on holiday on the north coast of France, as FØAKD, for most of August. He is keen to try skeds on 10GHz (both wb and nb) and 24GHz. Please contact Don on 0420 63315 for more info.

conventional'
17V
2A supply

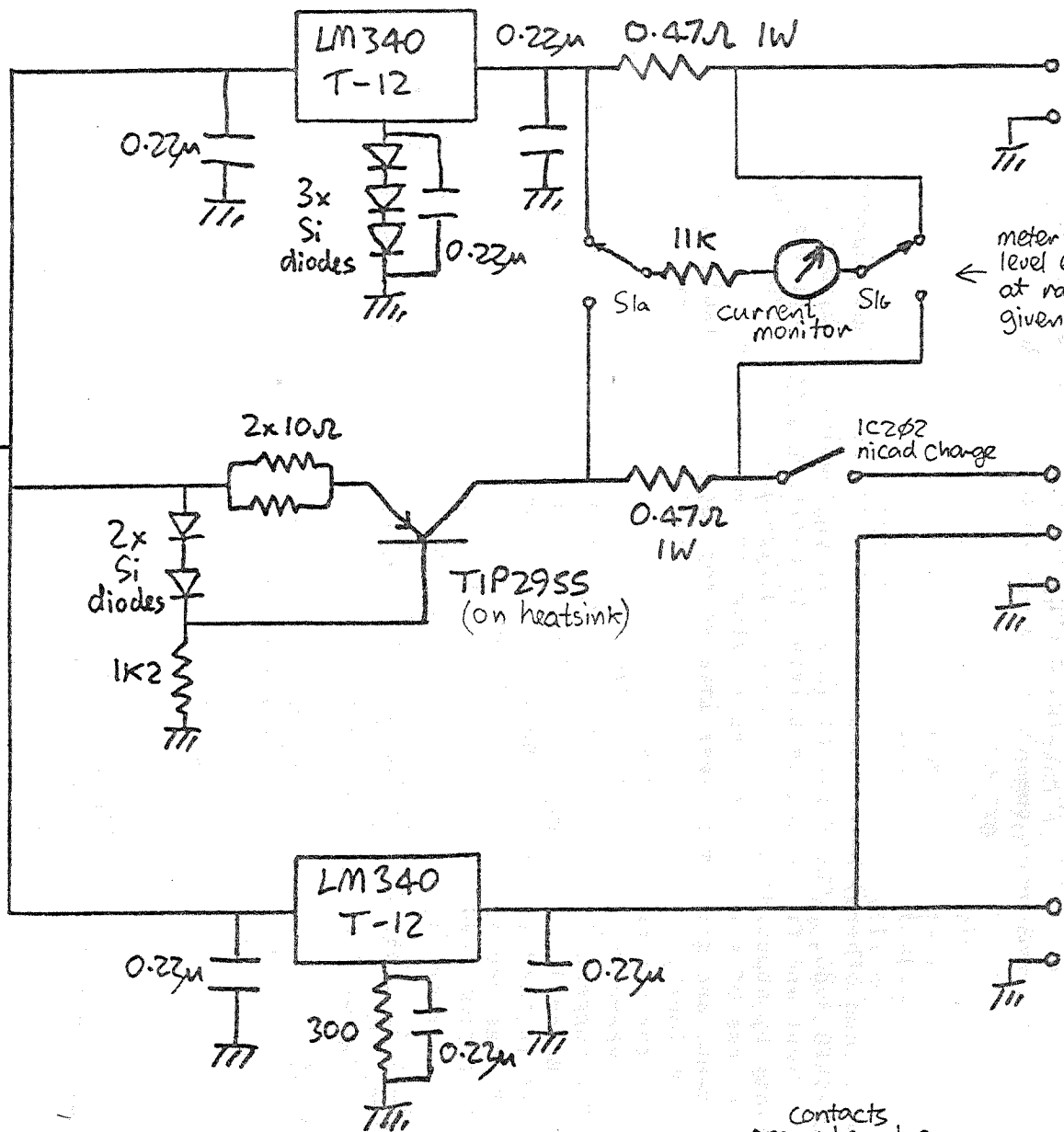

← ~14V constant-voltage to charge accumulator. LM340T12 current-limits at ~1A

← meter is small, cheap battery level edgewise meter, as available at rallies etc. With values given, it works out at ~1A f.s.d.

← ~200mA constant-current to charge 1C2Φ2 nicads
← 13.5V to power 1C2Φ2 while batteries are being charged

← 13.5V supply for other bits of equipment

New 1C2Φ2 power socket. (Seen from outside of 1C2Φ2) →

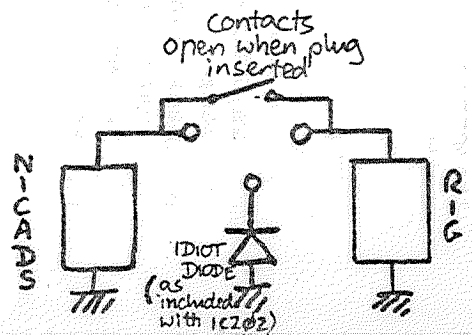

GACNV mains battery charger/psu

The above programme (see Microwave Newsletter 03-81) can be simplified and improved to include the whole area covered by the National Grid.

The simplification depends on the fact that all sensible computers represent the alphabet by a sequence of 26 binary numbers, but this sequence varies from machine to machine though the increment is constant for any machine. This increment is "B" - "A" and, for example ("X" - "A")/("B" - "A") = 23 for all machines.

The following notes are intended to help anyone adapt the programme section to varieties of BASIC. The same line numbers are used as in G4BGP's listing, so the material that is unchanged is not repeated here.

Line 100 determines the increments for the first and second letters of the N.G.R. respectively, it replaces the look-up table.

Line 110 obtains the integer corresponding to the first letter, i.e. 0 to 25 then, because "I" is not used, the value of "H" is fiddled to be consistent with the others. Line 112 evaluates the 500 km. steps in E and F using the following transformation:

H	J
N	O
S	T

8	9
13	14
18	19

0	500
0	500
0	500

&

1000	1000
500	500
0	0

Line 114 obtains the integer corresponding to the second letter, then reduces this value by one for all letters after "I" which is not valid. Line 116, which can be omitted, guards against this erroneous use of "I".

Line 119 increases E and F by multiples of 100 using the following transformation:

A	B	C	D	E
F	G	H	J	K
L	M	N	O	P
Q	R	S	T	U
V	W	X	Y	Z

0	1	2	3	4
5	6	7	8	9
10	11	12	13	14
15	16	17	18	19
20	21	22	23	24

&

4
3
2
1
0

0	1	2	3	4
0	1	2	3	4
0	1	2	3	4
0	1	2	3	4
0	1	2	3	4

Lines 120 adds the remainder of the reference and corresponds to the same line in the original listing. If your machine prefers one long formula, then lines 112, 119 and 120 can be combined.

The power of this method is that where the look-up table threatens to be very large, e.g. for QTH (QRA) or GEOREF, it saves having to compromise by omitting squares that are seldom needed.

23 PRINT "THAT IS NOT A VALID N.G.R."

```

100 LET X1 = "EA" - "AA" : LET X2 = "AE" - "AA"
110 LET N1 = INT((F$ - "AA")/X1) : IF N1 = 7 LET N1 = 8
112 LET E = 500 * (N1 - INT(N1/5) * 5 - 3) : LET F = 500 * (3 - INT(N1/5))
114 LET N2 = INT((E$ - "AA" - N1 * X1)/X2)
116 IF N2 = 8 THEN 23
118 IF N2 < 8 LET N2 = N2 - 1
119 LET E = E + 100 * (N2 - 5 * INT(N2/5)) : LET F = F + 100 * (4 - INT(N2/5))
120 LET E = E + INT(C/1000)/10 : LET F = F + C/10 - 100 * INT(C/1000)
140 RETURN
    
```

06/06/81

4th Cumulative Activity List

<u>Call</u>	<u>Telephone</u>	<u>Sites, Times of Operation and Equipment</u>
G2DSP		Trundle Hill, W. Sussex, SU877111
G3FYX	0454-778288	Cleeve Hill, Glous, S0997246, 10GHz wb, nbfm (phase mod) & nbcw, possibly 2.3GHz
G3JHM	0420-63315	Butser Hill, Hants, SU717204, and/or Grange Arch, Purbeck Hills, SY913818 if wx good. wb,nb
G3JVL	07016-4482	Hayling Island, Hants, SZ710992, wb, nb, 10GHz
G3LQC	0993-850576	Not yet decided, but possibly Stokenchurch
G3PFR	0928-88427	Winter Hill, Merryton Low, Axe Edge or Shropshire. wb
G3PHO	0742-681216	Winter Hill, SD660144, wb
G3YGF	0865-59988 ex348	Probably Mynydd Maen, ST260977, wb & nb (10W)
G3YJH	021-262-4979wk 054-33-4280	Titterstone Clee, Salop, S0601771, all day. wb and nb
G3WDG	0327-802100	Probably Walbury, SU374616, 10GHz, wb and nb, 2.3GHz
G4AUC	0344-20577	Batcombe Down, Dorset, wb ?
G4BGP		Furfield, nr Royston, TL320370, wb
G4ETU		Trundle Hill, W. Sussex, SU877111
G4KGC	0327-802100	Probably Walbury, SU374616, 10GHz, nb
G4KNZ	0344-23200	SW. Chilterns, Berks or Hants Downs
G4MBS (ex-G8ADP)	0420-62316	Upper Wield, Hants (home), SU634388, 2.3 and 10GHz, both 2W nb
G8AGN		Winter Hill, SD660144, 10GHz wb & possibly nb
G8GKV	0903-206384	Chanctonbury Ring, W. Sussex, TQ134120
G8HMV	0562-63090	Titterstone Clee, Salop, S0591779, wb?
G8MCQ		possibly Gibbet Hill, wb
G8SHF		possibly Win Green, Dorset, wb

NB : wb = wideband, nb = narrowband equipment. Please inform us of any corrections to the above data.