

Unexplored Areas of 432 MHz Feeds

Preface

Contemporary Electro Magnetic (EM) simulation software advances have made simulation of even large problems possible on desktop Personal Computers. A main frame computer is no longer needed for analysis like this. The accuracy of the simulations can be as good as the measurement accuracy on many antenna measurement ranges and probably better than on the average antenna test range. Not many antenna measurement ranges in the world will accommodate a 432 MHz feed and measure it with good accuracy. The measurement ranges that in fact can, are probably out of the reach of most radio amateurs. One has to remember that both simulations and measurements on a dedicated range will characterize the properties of a feed in another environment than it will be used in anyway. Still the accuracy of the results is good enough to be used for judgement of the feed qualities and for optimizing its performance. Having access to EM-simulation SW at work made me try to do some work in the 432 MHz feed area.

This paper addresses different properties of 432 MHz feeds that may not have been explored to a great extent before. It starts out with the basic radiating elements and their properties as a background for further in depth discussions on the specific issues.

Content

1 Background	2
2 Wanted Feed Properties	2
3 Basic Radiating Elements.....	2
4 How to Tame the Feed	3
4.1 Main Beam Properties	3
4.2 Cross Polar Discrimination	3
4.3 Side and Back Lobes	3
4.4 Feed losses.....	4
5 Putting the Feed in a Dish	4
5.1 Dish Reflexion.....	4
5.2 Feed Supports	5
6 Dual Band Configurations.....	7
7 Tolerances	9
8 Conclusion.....	12
9 References	12

1 Background

Looking into what feed to use for my 5.5 m 0.37 f/D dish on 432 MHz caught my interest for properties of the existing 432 MHz feeds. This need also opened my eyes for the possibility to make use of EM-simulation SW to get the info needed for making the right choice. It all resulted in the 432 MHz feed comparison report published on my web page in December 2010. http://2ingandlin.se/Feed_comp_432_MHz.html

This work also rendered in improved versions of two feeds; a loop feed with a one lambda reflector and a patch feed with a small reflector as well as the possibility to improve the performance of the Dual Dipole feed by using a baffle on the reflector.

From this work discussions have led to other 432 MHz feed areas and issues that could be explored with the aid of EM-simulation SW. This paper addresses some of these areas.

2 Wanted Feed Properties

Before we look into the details of feeds and the deeper questions and issues we stop for a moment and think about what we want from a feed for an EME dish.

- Optimum illumination of the dish
- No radiation outside the dish, both at the sides as well as backwards
- Low loss
- Minimal dimensions for less blocking as well as mechanical reasons
- Clean polarization properties (low cross polar radiation)
- Stable phase properties as function of illumination angle (Theta) in all Phi-cuts

Some of these basic requirements may be contradictory to each other. Even more so for some f/D - dish size combinations than other. We need to find the best compromise, as usual.

3 Basic Radiating Elements

So now when we know what we are looking for, let us see what basic radiating elements can be used in 432 MHz feeds:

- Dipole
- Loop
- Patch
- Annular Ring

Are there any fundamental differences between the basic radiating elements? Not really.

All exhibit a broader radiation pattern in the H-plane than in the E-plane. This fact need to be taken care of in order to fulfil the first and second criteria from above. One modern fable I heard was that a loop could be bent into an elliptic shape in order to equalize the E and H-plane beam widths. This is NOT true; the H-plane is still wider regardless how you shape the loop. Same thing considering a circular patch or not; the H-plane is still wider than the E-plane.

All of the radiating elements need a reflector in order to become a dish feed. The reflector design gives you some degree of freedom to optimize the performance to your specific needs. In general terms, a larger reflector gives a more narrow Beam Width (BW) and smaller reflector a wider BW. This paper will focus more on this issue later.

So, the choice of radiating element is more or less up to your preferences. Some small differences in the implementation may guide your choice. Some of the radiating elements are inherently more suited for the implementation of switchable dual polarization in a single element e.g. patch and annular ring.

4 How to Tame the Feed

Here is how to go from the basic radiating elements to a well functioning feed.

4.1 Main Beam Properties

As stated above, the BW in the E- and H-planes is not equal for any of the basic radiating elements. This is not acceptable as we want the illumination to be uniform in all Phi-cuts. If one of them is larger than the other you have to make a choice of f/D for either over illumination in one plane or under illumination in the other plane. You will never get the optimum illumination for both planes at the same time.

This was observed early and the dual dipole feed was created. Here two dipoles are stacked in the H-plane and thereby reducing the H-plane BW to be very close the E-plane BW. The dual dipole feed works very well with dishes with an f/D from below 0.45 to 0.55. Below 0.45 the dish starts to get under illuminated and the efficiency declines. Above 0.55 the dish is over illuminated and the antenna temperature starts to rise due to the spill over ground noise contribution.

Another way to reduce the H-plane BW to resemble the E-plane was suggested by Kildal in 1982 (Ref. 1) in the form of the Beam Forming Ring (BFR). With the BFR the H-plane BW becomes very close to the E-plane BW. The BFR can be used on dipoles, loops and patches with similar success. The performance of a dipole or loop with a BFR is very close the Dual Dipole feed and is suitable to the same f/D span.

If your dish is on the deep side you want to broaden the E-plane to resemble the H-plane and get a good illumination in the E-plane as well. In this case a smaller reflector together with a baffle on the reflector edge will reduce the E-plane BW to be close to the H-plane BW. Just using a smaller reflector with out the baffle will result in unequal BW in E- and H-planes as well as reduced Front to Back Ratio (FBR). The use of a small reflector with a baffle is well known in the literature. It has been called different names like cavity feed etc.

We have not yet seen any 432 MHz feed design that will match the 1296 MHz Kumar type Wave Guide feeds when it comes to efficiency. Here is clearly an area for further research.

4.2 Cross Polar Discrimination

Cross Polar Ratio (CPR) is a parameter that often is left out. In the main beam direction it does not do much harm except for stealing power from the wanted polarization if becoming extensive. In other directions the cross polarized radiation picks up as much noise as the wanted polarization and both of them need to be as low as possible.

One observation from the 432 MHz Feed comparison work is that feeds with elaborate matching and loading circuits' exhibit much worse CPR performance than a cleaner design. These circuits also tend to affect the symmetry of the feeds far field phase properties in an unfavourable way and the phase error may become extensive.

The use of a baffle on the reflector may help to clean up the CPR in some of these cases.

4.3 Side and Back Lobes

Excessive back lobes are mostly seen on feeds with small reflectors. In the case that the back lobe is in the order of 10 dB down from the main beam and exhibits about the same BW it "steals" about 0.4 dB of your power that will not reach the dish. It will radiate, but not in the direction of the dish and by that is doing no good for you.

Again, adding a baffle to the small reflector will improve the FBR dramatically. An FBR of 15 dB or better is a good figure to aim for and will give less than 0.15 dB of lost power.

Radiation at an angle larger than the rim of the dish (including side lobes) will eventually see the ground and pick up noise in the receive case. Keep this radiation as low as possible. This

is also a part of choosing the optimal feed for illuminating the dish in question as efficient as possible.

4.4 Feed losses

In order to get as much power as possible to the dish in the Tx case and keep the antenna temperature down in the Rx case, we want to reduce the resistive losses as much as we can. Most of the feed designs today are designed with low loss in mind and do have minimal losses. I tried to make an estimation of the losses by simulation, but the losses were so small that they almost disappeared in simulation accuracy of the feed. I think that most of the resistive losses comes from the cabling close to the radiating element rather than from the radiating element it self. Keep all cables as short as possible and do not use excessive amounts of connectors and coaxial adapters. Use highly conductive material and high quality dielectrics in your feed designs in order to keep the losses to a minimum.

5 Putting the Feed in a Dish

Now we know a lot about how to get the most out of the feed by itself. But, what may happen when we put the feed into our dish?

5.1 Dish Reflexion

When pointing a feed in the direction of the dish, a reflected wave from the dish will be present at the feed.

The magnitude of the reflexion from the dish is dependant on the wavelength, the focal length of the dish and the feeds gain in the direction of the vertex of the dish.

The following expression (from Ref. 2) can be used to calculate the reflexion coefficient from the dish present at the feed:

$$\Gamma = \frac{G\lambda}{4\pi f}$$

Where G is the gain (linear measure) of the feed in the direction of the vertex of the dish and f is the focal distance. This calculation is included in a small spread-sheet that can be found on my web page. <http://2ingandlin.se/Dish.xls>

A few 432 MHz examples: My 5.5 m dish with f/D of 0.37 (2.04 m focal length) with the BFR Loop feed will give a return loss of 12.9 dB from the dish reflexion alone. An 8 m dish with an f/D of 0.45 (3.6 m focal length) and a Dual Dipole feed will give a dish return loss of 16.1 dB. Values like this can clearly be seen on your SWR-meter and may deteriorate your stations performance. Tuning the feed in the dish is a delicate problem and need some work to find a practical solution to.

Peter Blair, G3LTF, presented a paper on this issue using a stub: A Modified Dual Dipole Dish Feed for 432 MHz,

<http://www.vk3um.com/G3LTF%20432%20eme%20feed%20v4.pdf>.

Gerald, K5GW, reports that adjusting the feed to dish distance is a way to tune the match by getting the reflected wave out of phase with the inherent reflection of the feed. In this case you need to pay attention to the focal distance and the Phase Centre of the feed while tuning.

OK1DFC reports going from 30 dB return loss for the feed in free space to 50 dB when mounted in the focal point of the dish.

The situation for 1296 MHz is much better thanks to the shorter wave length. For the same size dishes a VE4MA type feed in my 5.5 m dish will give about 28 dB dish return loss and the 8 m, 0.45 f/D, with a W2IMU dual mode feed about 26 dB dish return loss. Much better than on 432 MHz, but as you most probably have a circular polarized feed the reflected wave will not be seen on the Tx port but on the Rx-port due to the rotation reversal at the dish reflexion. This will affect the Tx to Rx isolation performance of a feed mounted in the dish compared to any bench measurements.

5.2 Feed Supports

In order to place the feed in a dish some kind of support is needed to keep it in the proper place. Have you ever wondered how this may interfere with the radiation properties of the feed? Will it destroy the good performance of the feed itself?

Many different cases and configurations may exist; I just took an example in order to illustrate what can be expected.

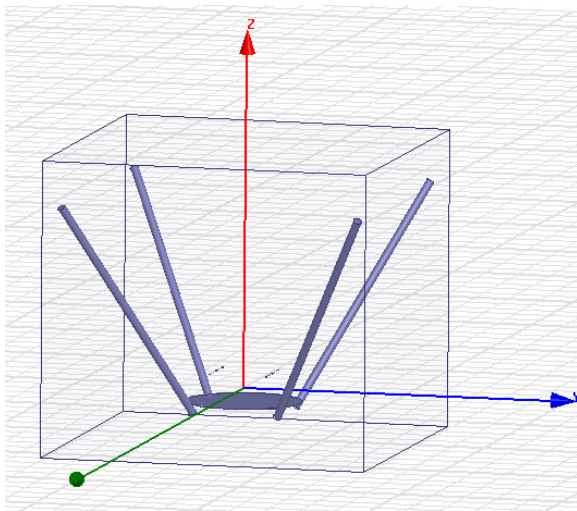

The model for the simulated feed support structure consists of four PEC (Perfect Electrical Conductor, ~metallic) tubes with a diameter of 50 mm and a length of 1600 mm. The feed is a dual dipole feed with one lambda circular reflector.

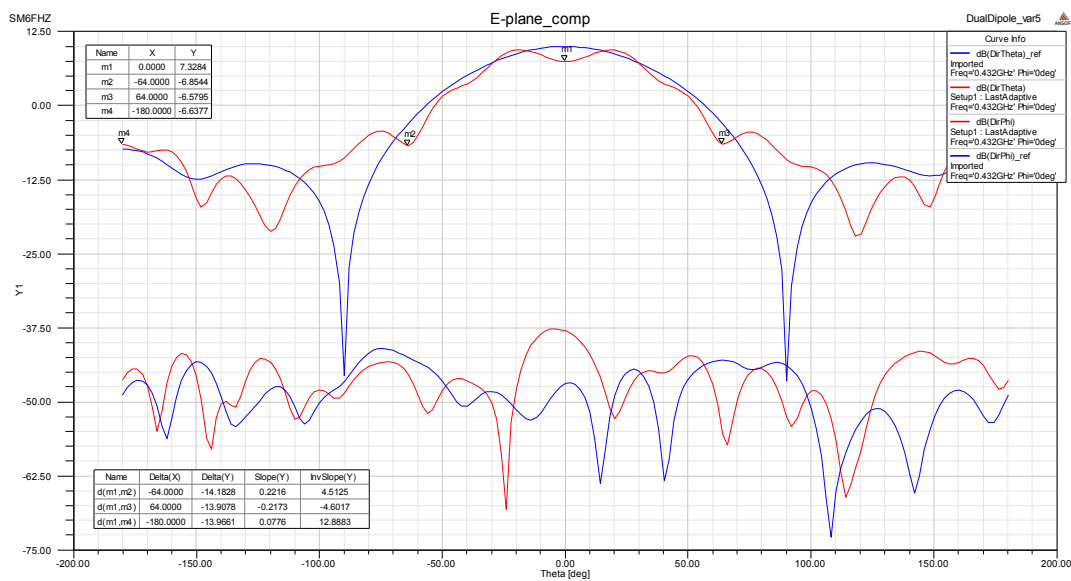

E-plane radiation plots for Co and Cross-polarization. Blue curve is the reference feed without the support structure and the red curves are the pattern for the feed including the feed support.

As can be seen in the E-plane radiation plot some interference arises, the null depth at 90 degrees offset is filled out and the FBR is slightly reduced. The CPR is not affected to any large degree by the feed support.

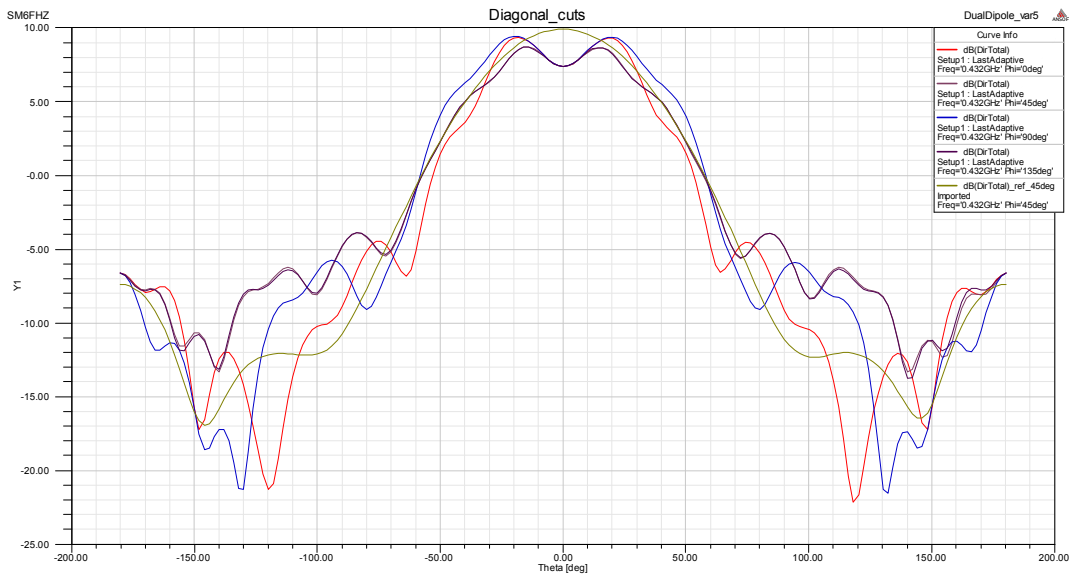

Radiation plots
Total Power at
Phi=0, 45, 90 and
135 deg.
Green curve is the
reference feed at
Phi=45 deg
without the support
structure and the
remaining four
curves are the
pattern for the feed
including the feed
support.

Dual Dipole circular reflector

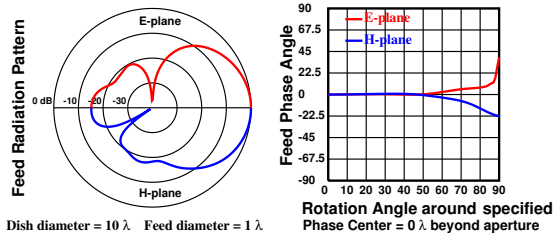

Dish diameter = 10 λ. Feed diameter = 1 λ.

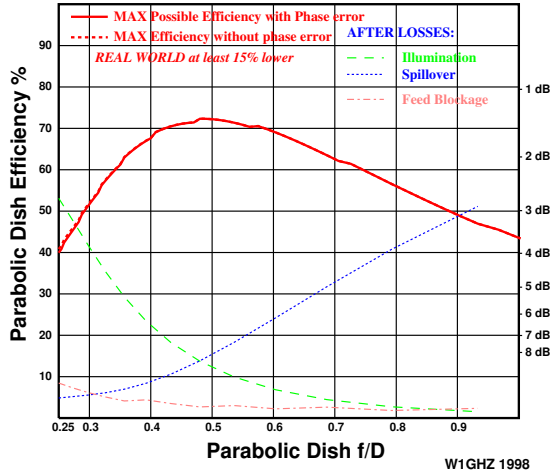

Dual Dipole w. support legs

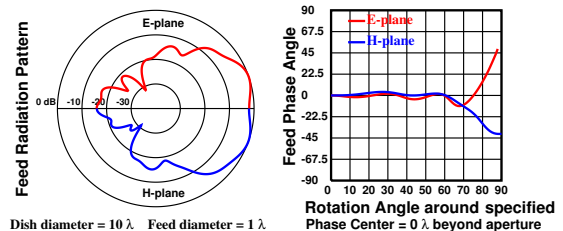

Dish diameter = 10 λ. Feed diameter = 1 λ.

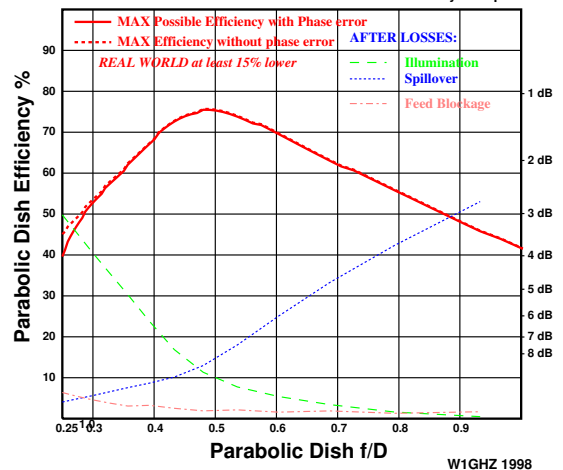

As can be seen in the two Dish Efficiency graphs (generated by Phasepat.exe from W1GHZ, ref.3), the support does not destroy the performance of the Dual Dipole feed. On the contrary it actually improves the efficiency by close to 5 percent units at an f/D of slightly below 0.5. The spill-over (antenna noise performance) is not negatively impacted either.

It is very clear that the four Wave Guiding Rods (WGR) do improve the performance of a prime focus fed parabolic dish. This configuration can be varied in order to optimize the overall performance of similar configurations.

6 Dual Band Configurations

One common Dual Band configuration for 432 MHz together with 1296 MHz is the Dual Dipole feed on 432 MHz and the W2IMU Dual Mode horn on 1296 MHz. Does the presence of the Dual Mode feed horn in the middle of the 432 MHz feed aperture makes any difference to the radiation properties of the Dual Dipole feed?

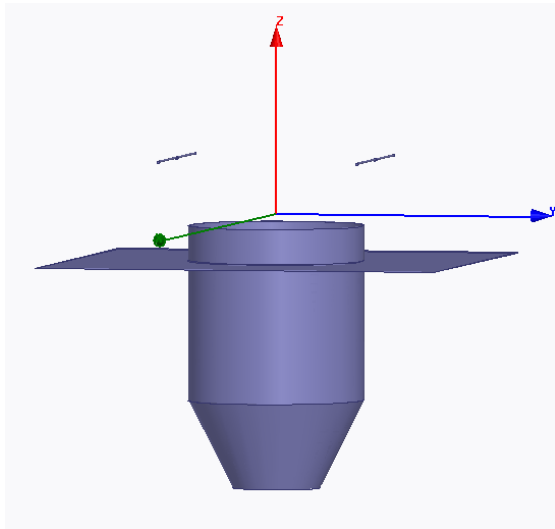

The simulation model consists of two dipoles above a square reflector and the WG mouth part of the Dual Mode feed. The mouth of the 23 cm feed is 60 mm above the reflector surface.

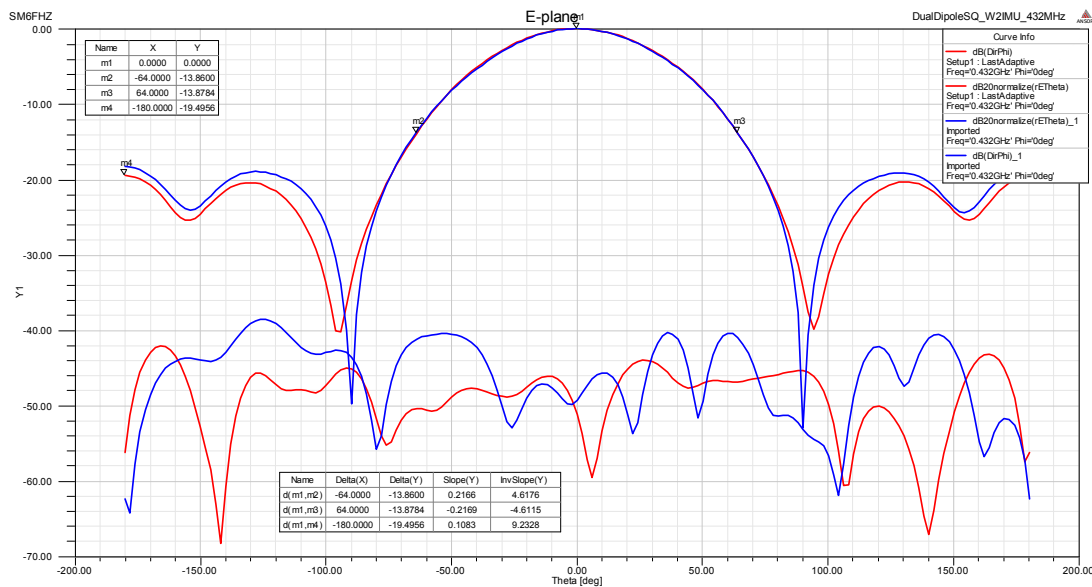

The blue curves are the reference feed without 23 cm horn and the red curves are the pattern for the feed with the 23 cm feed horn 60 mm above the reflector surface.

As can be seen in the graphs the performance of the 70 cm feed is not degraded by the introduction of a 23 cm feed in the centre of the reflector. Contrary, it is slightly better with respect to spill-over and FBR.

However, with this placement of the 23 cm feed mouth 60 mm above the reflector surface the phase centre of the two feeds are not in the same place. Moving the 23 cm feed another 20 mm forward the two phase centres will coincide. Radiation performance for this 23 cm feed position is still as good as the original 70 cm feed as can be seen in the following graphs.

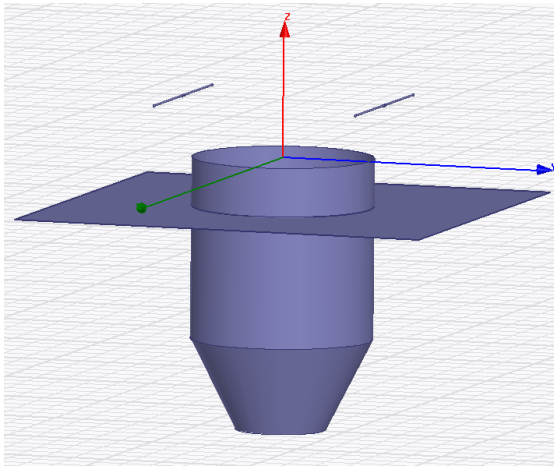

The simulation model consists of two dipoles above a square reflector and the WG mouth part of the Dual Mode feed. The mouth of the 23 cm feed is 80 mm above the reflector surface.

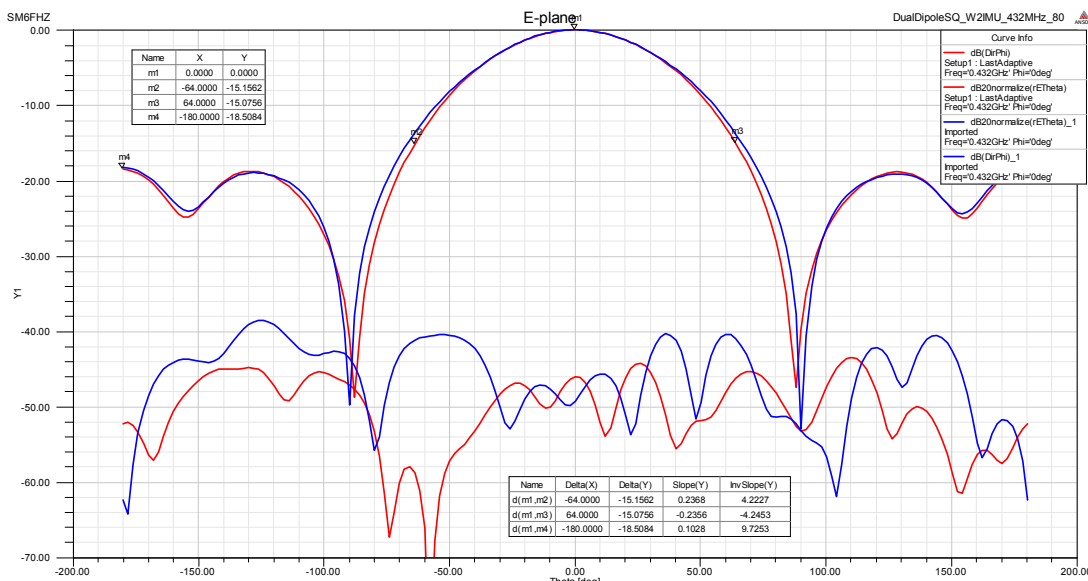

The blue curves are the reference feed without 23 cm horn and the red curves are the pattern for the feed with 23 cm feed horn 80 mm above the reflector surface.

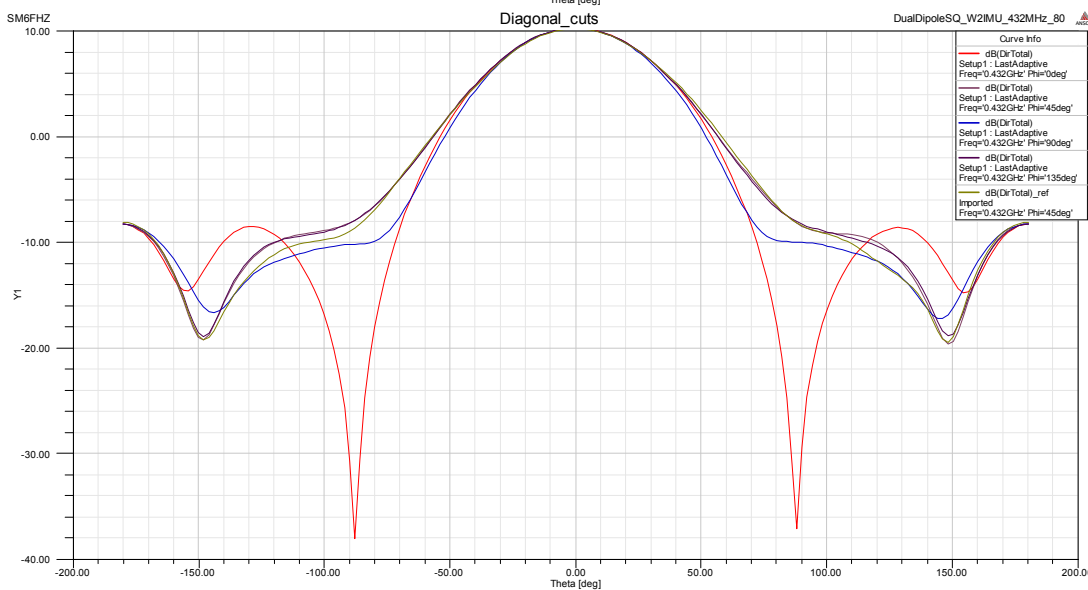

Total Power radiation plots at $\Phi=0, 45, 90$ and 135 deg. The green curve is the reference feed at $\Phi=45$ deg without 23 cm horn and the remaining curves are the patterns for the feed with 23 cm feed horn 80

Not much of impact from the 23 cm feed can be seen in the diagonal cuts either.

Impact on the 23 cm dual mode feed performance in the dual band configuration will have to wait until a future report.

7 Tolerances

How sensitive is the RF-performance of the feeds to mechanical tolerances? A few simulations reveal how careful you need to be in order to succeed in your feed project. The feed that serves as an example is the Dual Dipole Feed with one lambda circular reflector.

Reflector size: By varying the reflector radius in the simulation and studying the radiation properties one can get a grasp of how sensitive the feed is for such variations.

As can be seen from the graphs this feed is quite insensitive for these variations. The H-plane variation performance resembles the E-plane performance shown in the graphs.

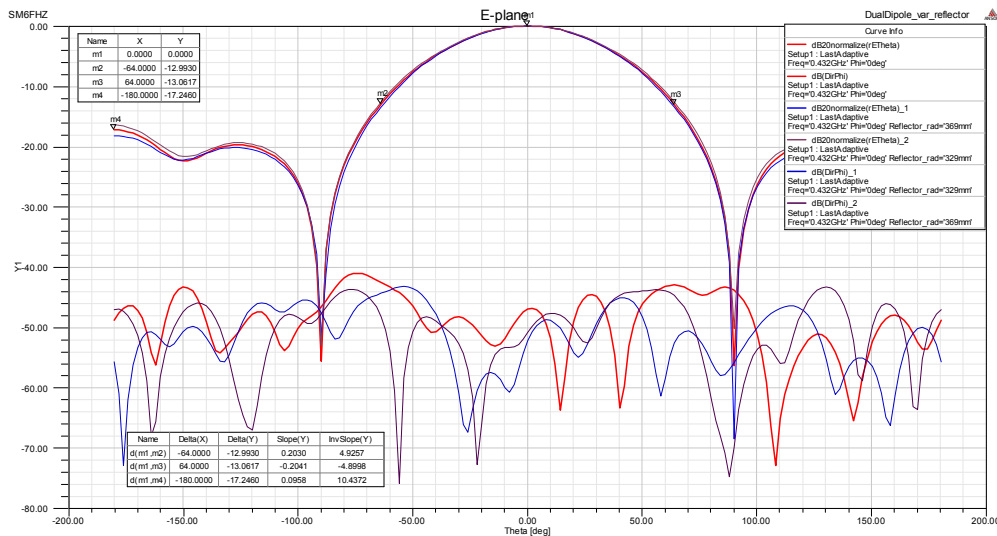

E-plane radiation pattern for Co- and Cross-polarization. The red curves are the reference feed with nominal and the brown are the pattern for 20mm larger radius and the blue are the pattern for 20mm smaller radius.

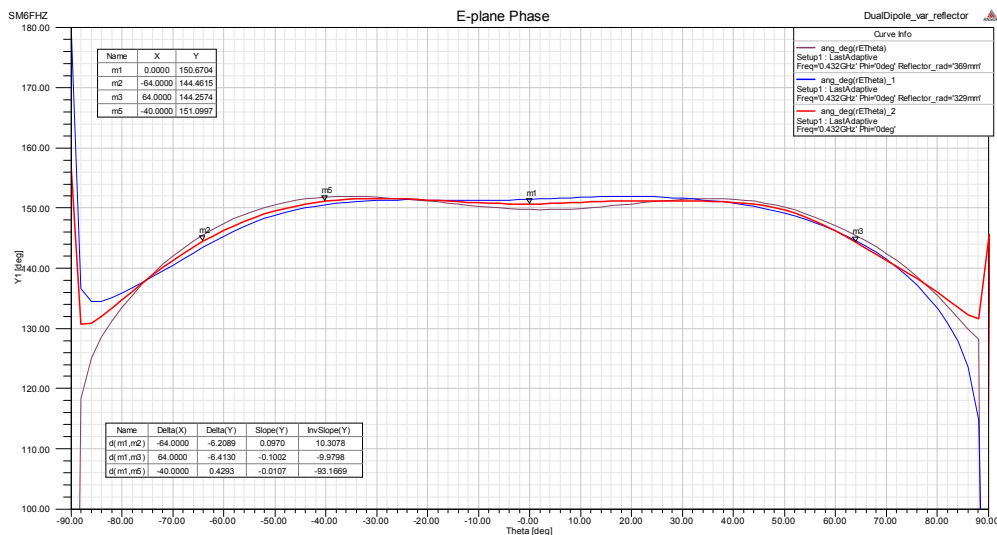

E-plane phase error as function of illumination angle. The red curve is the reference feed with nominal and the brown is the pattern for 20mm larger radius and the blue is the pattern for 20mm smaller radius.

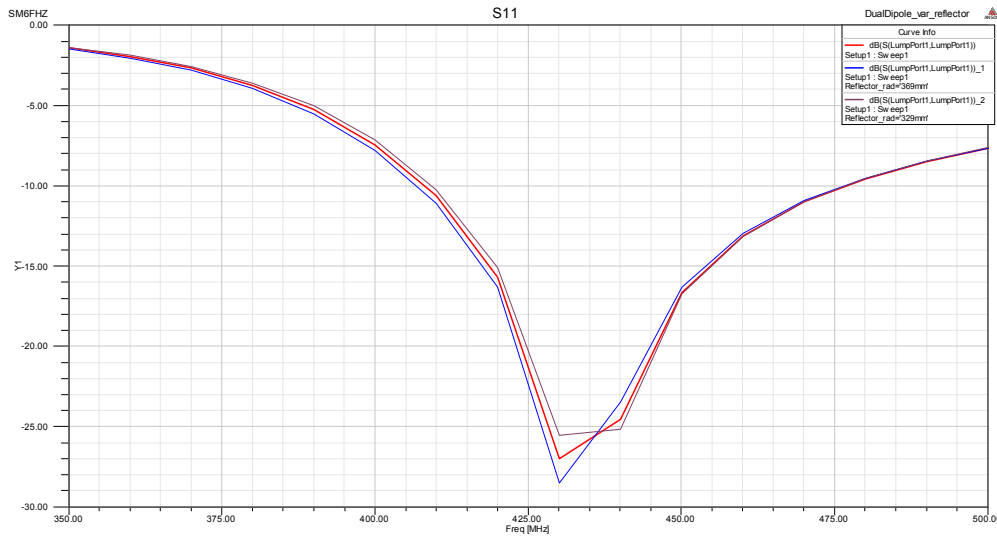

Return Loss for one of the dipoles. The red curve is the reference feed with nominal and the blue is the pattern for 20mm larger radius and the brown is the pattern for 20mm smaller radius.

Dipole height: Varying the dipole height over the reflector in the simulation and studying the variation in radiation properties show how sensitive the feed is for this variation. The feed is quite insensitive to these variations as well.

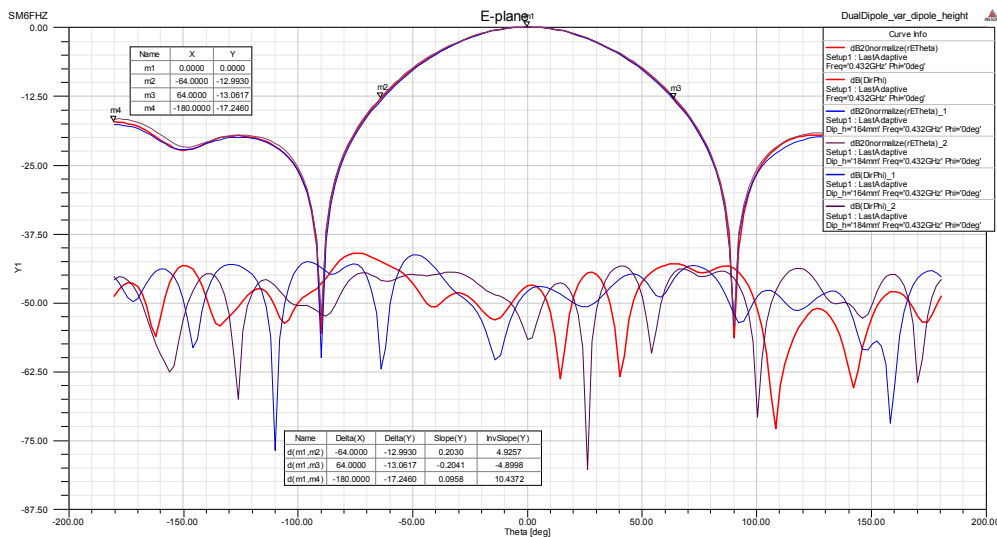

E-plane radiation pattern for Co- and Cross-polarization. The red curves are the reference feed with nominal and the brown are the pattern for 10mm larger distance and the blue are the pattern for 10mm smaller distance.

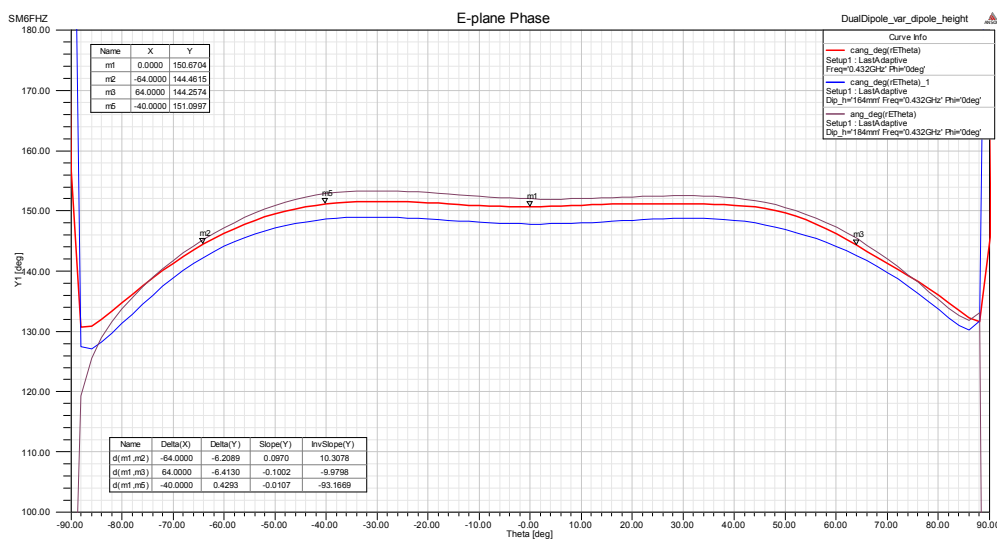

E-plane phase error as function of illumination angle. The red curve is the reference feed with nominal and the brown is the pattern for 10mm larger distance and the blue is the pattern for 10mm smaller distance.

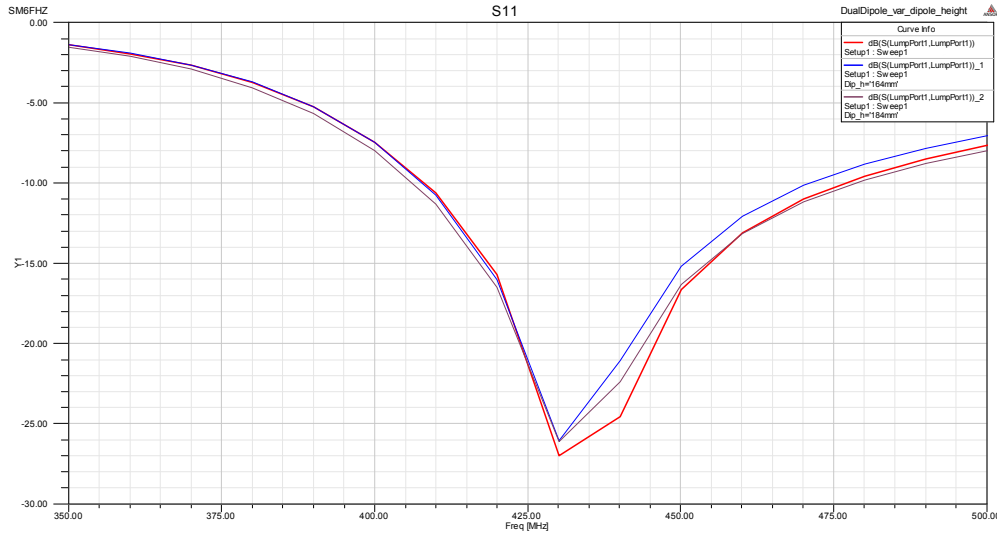

Return Loss for one of the dipoles. The red curve is the reference feed with nominal and the brown is the pattern for 10mm larger distance and the blue is the pattern for 10mm smaller distance.

Dipole length: The dipole length determines the resonance frequency. A variation of the length of the dipole shifts the frequency for best impedance match. The feeds radiation properties are quite insensitive to the dipole length variations as well.

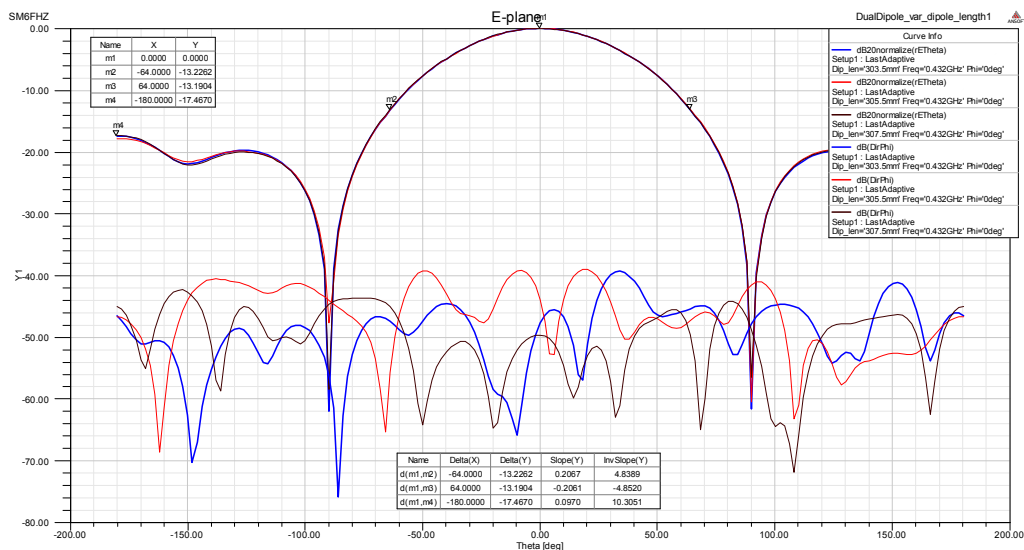

E-plane radiation pattern for Co- and Cross-polarization. The red curves are the reference feed with nominal and the brown are the pattern for 2mm larger length and the blue are the pattern for 2mm smaller length.

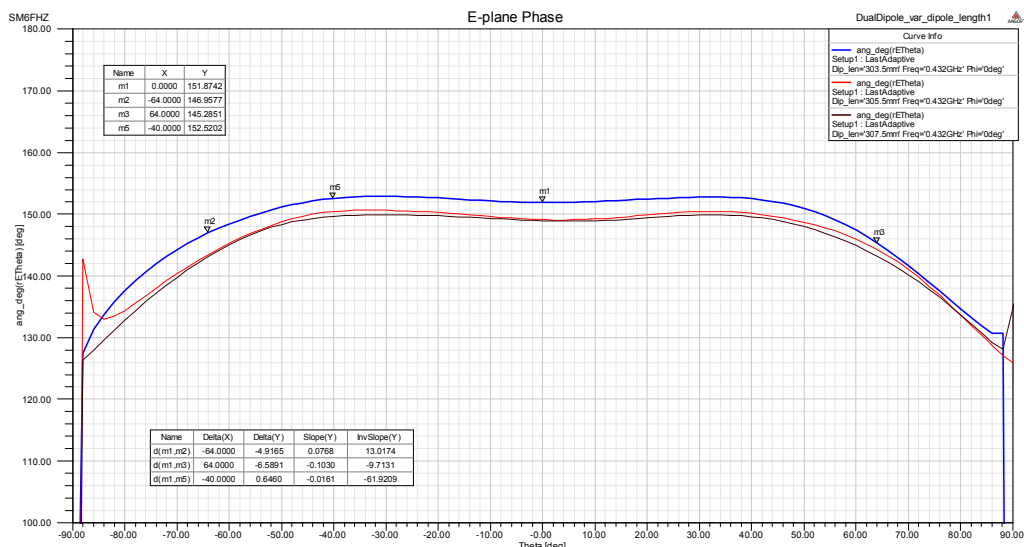

E-plane phase error as function of illumination angle. The red curve is the reference feed with nominal and the brown is the pattern for 2mm larger length and the blue is the pattern for 2mm smaller length.

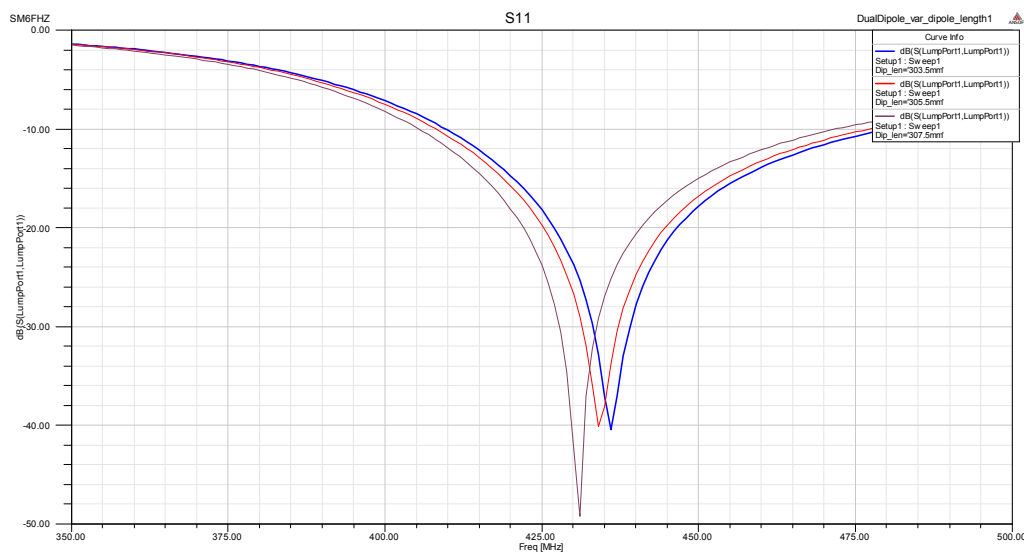

Return Loss for one of the dipoles. The red curve is the reference feed with nominal and the brown is the pattern for 2mm larger dipole length and the blue is the pattern for 2mm smaller dipole length.

We can conclude that this feed is quite insensitive to moderate variations in the dimensions. The variation in radiation pattern is very small for all three of these variations in dimension. The phase centre does not change to any extent that will alter the feed performance in the dish. The resonance frequency of the dipole changes as expected with the variation of the dipole length.

8 Conclusion

In this paper a few hints on the ideas behind how to plan and choose the feed for your dish has been given. You can make a few choices when you plan your dish feed that will improve the end result if done in a sensible way.

It has been shown that a configuration of four Wave Guiding Rods do improve the efficiency of a prime focused fed parabolic dish.

By just scratching the surface of the myriad of possible tolerance variations, one can see that it must not be that catastrophic but can indeed explain some loss experienced in a real world installation scenario. In fact the Dual Dipole Feed shows only a small sensitivity to moderate variations of the dimensions. It is sensible to believe that other similar feeds exhibit the same behaviour.

I hope this paper will help and inspire some moonbouncers to take the next step and upgrade their dish with a feed for 432 MHz.

9 References

1. Dipole-Disk Antenna with Beam-Forming Ring, Per-Simon Kildal, Svein A. Skyttemyr, IEEE Transactions on Antennas and Propagation, Vol. AP-30, No. 4, July 1982, page 529 - 534
2. Antenna Engineering Handbook, H. Jasik et Al, McGraw-Hill Book Company, First Edition 1961
3. Phasepat.exe, W1GHZ, On line Antenna book.